

Type code for standard program

A

2

PA10VSO

1	2	3	4	5	6	7	8	9	10	11	12	13		
Version									18	28	45	71	100	140
9	Splined shaft ANSI B92.1a	standard shaft		■	■	■	■	■	■	■	■	S	※	
		similar to shaft "S" however for higher input torque reduced diameter, not for through drive		■	■	■	■	-	-	-	-	-	R	
		reduced diameter, not for through drive		■	△	△	△	■	-	-	-	-	U	
		same as "U", higher torque; not for through drive		-	△	△	△	△	△	-	-	-	W	
	Parallel keyed shaft Not for through drive		Metric DIN 6885 SAE ISO 3019-1		■	■	■	■	■	■	■	■	P	※
				■	■	■	■	■	■	■	■	K		

Note: Same splined shaft for SAE/Metric

Mounting flange 18 28

18	28	45	71	100	140					
10	ISO 3019-2 (Metric)	2-hole		■	■	■	■	■	-	A
		4-hole		-	-	-	-	-	■	B
	ISO 3019-1 (SAE)	2-hole		■	■	■	■	■	-	C ³⁾
		4-hole		-	-	-	-	-	■	D ³⁾

Service line port

18	28	45	71	100	140					
11	SAE flange ports on opposite side,metric-fastening thread			■	■	■	-	■	■	12
				-	-	-	■	-	-	42
	SAE flange ports on opposite side,UNC fastening thread			■	■	■	-	■	■	62 ³⁾
				-	-	-	■	-	-	92 ³⁾

Through drive

18	28	45	71	100	140							
12	without through drive		■	■	■	■	■	■	■	N00	※	
	Flange ISO 3019-1 Diameter	coupling for splined shaft ¹⁾ diameter										
		82-2 (A)	5/8 in	9T 16/32DP	■	■	■	■	■	■	K01	
		3/4 in	11T 16/32DP	■	■	■	■	■	■	K52		
	101-2 (B)	7/8 in	13T 16/32DP	-	■	■	■	■	■	■	K68	
		1 in	15T 16/32DP	-	-	■	■	■	■	■	K04	
	127-2 (C)	1 1/4 in	14T 12/24DP	-	-	-	■	■	■	■	K07	
		1 1/2 in	17T 12/24DP	-	-	-	-	■	■	■	K24	
	152-4 (D)	1 3/4 in	13T 8/16DP	-	-	-	-	-	■	■	K17	
	Ø 63 , Metric 4 hole		key shaft Ø 25		-	△	△	△	△	△	K57	
	Flange ISO 3019-2 Diameter											
		80 , 2-hole	3/4 in	11T 16/32DP	△	△	△	△	△	△	KB2	
	100 , 2-hole	7/8 in	13T 16/32DP	-	△	△	△	△	△	△	KB3	
		1 in	15T 16/32DP	-	-	△	△	△	△	△	KB4	
	125 , 2-hole	1 1/4 in	14T 12/24DP	-	-	-	△	△	△	△	KB5	
		1 1/2 in	17T 12/24DP	-	-	-	-	△	△	△	KB6	
	180 , 4-hole	1 3/4 in	13T 8/16DP	-	-	-	-	-	△	△	KB7	

Connectors for solenoids ²⁾

18	28	45	71	100	140						
13	HIRSCHMANN connector – without suppressor diode					-	-	-	-	-	H

■ = available - = on request ※ = standard type △ = custom made

SAE —

Technical data

Hydraulic fluid

When using environmentally acceptable hydraulic fluids, the limitations regarding technical data and seals must be observed. Please contact us. When ordering, indicate the hydraulic fluid that is to be used.

Operating viscosity range

For optimum efficiency and service life we recommend that the operating viscosity (at operating temperature) be selected in the rang

$$V_{opt} = \text{opt. operating viscosity } 80 - 170 \text{ SUS } (16 \dots 36 \text{ mm}^2/\text{s})$$

referred to reservoir temperature (open circuit).

Limits of viscosity range

For critical operating conditions the following values apply:

$$n_{min} = 60 \text{ SUS } (10 \text{ mm}^2/\text{s})$$

short-term ($t \leq 1 \text{ min}$)

at max perm. case drain temp. of 195°F (90 °C).

Please also ensure that the max. case drain Ztemperature of 195 °F (90 °C) is not exceeded in localized areas (for instance, in the bearing area). The fluid temperature in the bearing area is approx. 7 °F (5 K) higher than the average case drain temperature

$$n_{max} = 4640 \text{ SUS } (1000 \text{ mm}^2/\text{s})$$

short-term ($t \leq 1 \text{ min}$)

on cold start

($p \leq 435 \text{ psi } (30 \text{ bar}), n \leq 1000 \text{ rpm}, t_{min} -13^\circ\text{F } (-25 \text{ }^\circ\text{C})$).

Depending on the installation situation, special measures are necessary at temperatures between -40 °C and -25 °C). Please contact DYNATEC.

Selection diagram

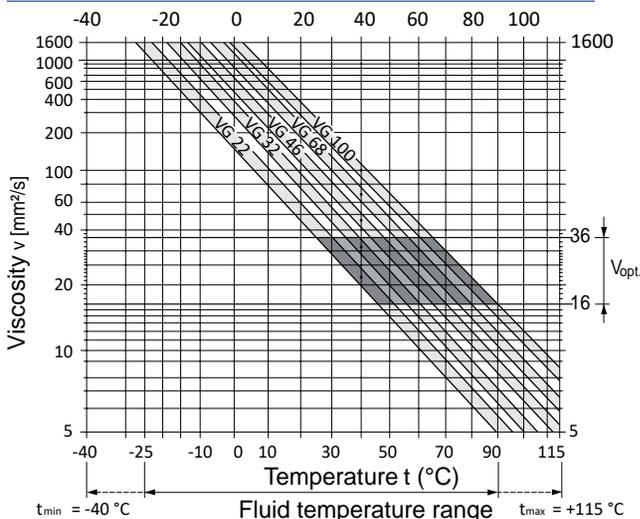

Notes on the choice of hydraulic fluid

In order to select the correct hydraulic fluid, it is necessary to know the operating temperature in the reservoir (open circuit) in relation to the ambient temperature.

The hydraulic fluid should be selected so that within the operating temperature range, the viscosity lies within the optimum range (v_{opt}), see shaded section of the selection diagram. We recommend to select the higher viscosity grade in each case.

Example: at an ambient temperature of X °F (°C) the operating temperature is 140 °F (60 °C). In the optimum operating viscosity range (v_{opt} ; shaded area) this corresponds to viscosity grades VG 46 resp. VG 68; VG 68 should be selected.

Filtration of the hydraulic fluid

The finer the filtration the better the cleanliness level of the hydraulic fluid and the longer the service life of the axial piston unit. In order to guarantee the functional reliability of the axial piston unit it is necessary to carry out a gravimetric evaluation of the hydraulic fluid to determine the particle contamination and the cleanliness level according to ISO 4406. A cleanliness level of at least 20/18/15 must be maintained. At very high hydraulic fluid temperatures (195 °F (90 °C) to maximum 239 °F (115 °C)), a cleanliness level of at least 19/17/14 according to ISO 4406 is necessary. If the above cleanliness levels cannot be maintained, please contact us.

Important

The case drain temperature is influenced by pressure and input speed and is always higher than the reservoir temperature. However, at no point in the component may the temperature exceed 195 °F (90 °C). The temperature difference specified on the left is to be taken into account when determining the viscosity in the bearing.

If the above conditions cannot be met, due to extreme operating parameters please contact us.

Technical data

A

4

PA10VSO

Operating pressure range

- Pressure at service line port B
 - Nominal pressure p_{nom} _____ 4000 psi (280 bar) absolute
 - Maximum pressure p_{max} _____ 5100 psi (350 bar) absolute
 - Single operating period _____ 2.5 ms
- Total operating period _____ 300 h

Min. pressure (high-pressure side) _____ 145 psi (10 bar) absolute¹⁾

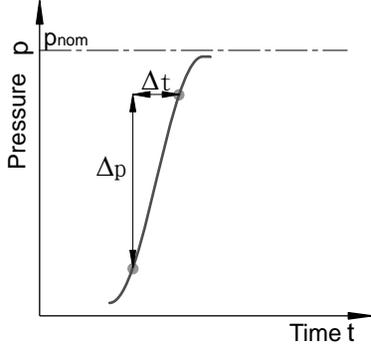

Pressure at suction port S (inlet)

- Minimum pressure $P_S \min$ _____ 12 psi (0.8 bar) absolute
- Maximum pressure $P_S \max$ _____ 145 psi (10 bar)¹⁾ absolute

Note

Please contact us for values for other hydraulic fluids.

Case drain pressure

Maximum permissible case drain pressure (at port L · L1) :
 Maximum 7 psi (0.5 bar) higher than the inlet pressure at port S, however not higher than 30 psi (2 bar) absolute.

$P_{L \max \text{ abs}}$ _____ 2 bar absolute¹⁾

¹⁾Other values on request

Definition

■ Nominal pressure p_{nom}

The nominal pressure corresponds to the maximum design pressure.

■ Maximum pressure p_{max}

The maximum pressure corresponds to the maximum operating pressure within the single operating period. The total of the single operating periods must not exceed the total operating period.

■ Minimum pressure (high-pressure side)

Minimum pressure in the high-pressure side (port B) that is required in order to prevent damage to the axial piston unit. The minimum pressure depends on the speed and displacement of the axial piston unit.

■ Rate of pressure change RA

Maximum permissible pressure build-up and pressure reduction speed with a pressure change over the entire pressure range.

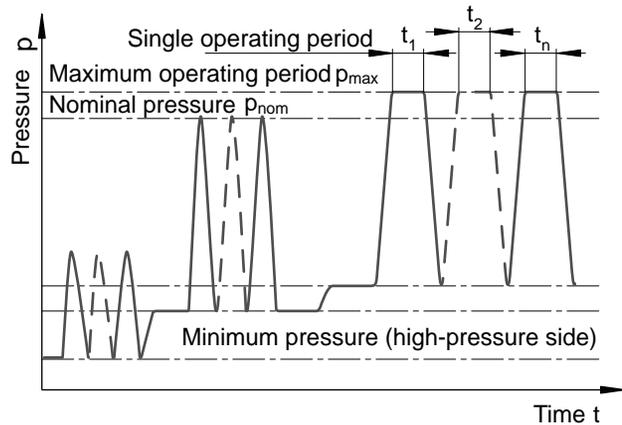

Total operating period = $t_1 + t_2 + \dots + t_n$

Technical data, standard unit

Table of values (theoretical values, without efficiencies and tolerances: values rounded)

Size	NG	18	28	45	71	100	140		
Geometrical displacement per revolution	$V_g \text{ max}$	in ³ (cm ³)	1.10(18)	1.71(28)	2.75(45)	4.33(71)	6.10(100)	8.54(140)	
Speed ¹⁾									
maximum at $V_g \text{ max}$	n_{nom}	rpm	3300	3000	2600	2200	2000	1800	
maximum at $V_g < V_g \text{ max}$	$n_{\text{max perm}}$	rpm	3900	3600	3100	2600	2400	2100	
Flow									
n_{nom} and $V_g \text{ max}$	$q_v \text{ max}$	gpm (l/min)	15.7 (59)	22 (84)	31 (117)	41 (156)	53 (200)	67 (252)	
$n_E = 1800 \text{ rpm}$ and $V_g \text{ max}$	$q_{vE} \text{ max}$	gpm (l/min)	7.2 (32)	13.3 (59)	21.4 (81)	33.8 (128)	47.6 (180)	67 (252)	
Power at $\Delta p = 4000 \text{ psi}$ (280 bar) at n_{nom} and $V_g \text{ max}$	P_{max}	HP (kW)	36 (28)	51 (39)	72 (55)	96 (73)	124 (93)	156 (118)	
$n_E = 1500 \text{ rpm}$ and $V_g \text{ max}$	$P_{E \text{ max}}$	HP (kW)	19 (15)	31 (24)	50 (38)	91 (69)	111 (84)	156 (118)	
Torque									
$V_g \text{ max}$ and $\Delta p = 4000 \text{ psi}$ (280 bar)	T_{max}	lb-ft (Nm)	58 (80)	91 (125)	146 (200)	230 (316)	324 (445)	453 (623)	
$\Delta p = 1450 \text{ psi}$ (100 bar)	T	lb-ft (Nm)	14.6 (30)	33 (45)	53 (72)	83 (113)	117 (159)	164 (223)	
Rotary stiffness, drive shaf	S	C	lb-ft/rad (Nm/rad)	8082 (11087)	16400 (22317)	27560 (37500)	53018 (71884)	89348 (121142)	125042 (169537)
	R	C	lb-ft/rad (Nm/rad)	10870 (14850)	19400 (26360)	30240 (41025)	56456 (76545)	- (-)	- (-)
	P	C	lb-ft/rad (Nm/rad)	- (13158)	- (25656)	- (41232)	- (80627)	- (132335)	- (188406)
	U	C	lb-ft/rad (Nm/rad)	5946 (8090)	- (-)	- (-)	- (-)	67180 (91093)	- (-)
	K	C	lb-ft/rad (Nm/rad)	9805 (13340)	19712 (26189)	32270 (43905)	60352 (82112)	99448 (135303)	144680 (188406)
Moment of inertial rotary group	J_{TW}	lbs-ft ² (kgm ²)	0.022 (0.00093)	0.0403 (0.0017)	0.0783 (0.0033)	0.1970 (0.0083)	0.3963 (0.0167)	0.5743 (0.0242)	
Angular acceleration, maximum ²⁾	α	rad/s ²	6800	5500	4000	3300	2700	2700	
Filling capacity	V	gal (L)	01.(0.4)	0.2(0.7)	0.26(1.0)	0.4(1.6)	0.6(2.2)	0.8(3.0)	
Weight (without through drive)	m	lbs (kg)	26.5(12)	33(15)	46(21)	73(33)	99(45)	132(60)	

The values are applicable :

- ¹⁾- for an absolute pressure $p_{\text{abs}} = 15 \text{ psi}$ (1 bar) at suction port S
- within the optimum viscosity range from $\nu_{\text{opt}} = 80$ to 170 SUS (16 to $36 \text{ mm}^2/\text{s}$)
- for mineral-oil based hydraulic fluid.

²⁾The scope of application lies between the minimum necessary and the maximum permissible drive speeds. Valid for external excitation(e.g. diesel engine 2- to 8-fold rotary frequency, cardan shaft 2-fold rotary frequency). The limiting value is only valid for a single pump. The loading capacity of the connecting parts must be taken into account.

Note

Exceeding the maximum or falling below the minimum permissible values can lead to a loss of function, a reduction in operational life or total destruction of the axial piston unit. We recommend to check the loading through tests or calculation / simulation and comparison with the permissible values.

Determination of size

Flow	$q_v = \frac{V_g \cdot n \cdot \eta_v}{231(1000)}$	[gpm l/min]	V_g = Displacement per revolution in in ³ (cm ³) Δp = Differential pressure in psi (bar)
Torque	$T = \frac{V_g \cdot \Delta p}{24(20) \cdot p \cdot h_{mh}}$	[lb-ft Nm]	n = Speed in rpm (rpm) η_v = Volumetric efficiency
Power	$P = \frac{2\pi \cdot T \cdot n}{33000(60000)} = \frac{q_v \cdot \Delta p}{1714(600) \cdot \eta_t}$	[HP kW]	η_{mh} = Mechanical-hydraulic efficiency η_t = Total efficiency ($\eta_t = \eta_v \cdot \eta_{mh}$)

Technical data, high-speed version

Table of values (theoretical values, without efficiencies and tolerances: values rounded)

Size	NG		45	71	100	140
Geometrical displacement per revolution	$V_{g \max}$	in ³ (cm ³)	2.75(45)	4.33(71)	6.1(100)	8.54(140)
Speed ¹⁾						
maximum at $V_{g \max}$	n_{nom}	rpm	3000	2550	2300	2050
maximum at $V_g < V_{g \max}$	$n_{\text{max perm}}$	rpm	3300	2800	2500	2200
Flow						
n_{nom} and $V_{g \max}$	$q_{v \max}$	gpm (l/min)	35 (135)	48 (178)	61 (230)	76 (287)
Power at $\Delta p = 4000$ psi (280 bar) at n_{nom} and $V_{g \max}$	P_{max}	HP (kW)	83 (63)	112 (83)	142 (107)	177 (134)
Torque						
$\Delta p = 4000$ psi (280 bar)	T_{max}	lb-ft (Nm)	146 (200)	230 (316)	324 (445)	453 (623)
$V_{g \max}$ and $\Delta p = 1450$ psi (100 bar)	T	lb-ft (Nm)	53 (72)	83 (113)	117 (159)	164 (223)
Rotary stiffness, drive shaf						
S	C	lb-ft/rad (Nm/rad)	27560 (37500)	53018 (71884)	89348 (121142)	125042 (169537)
R	C	lb-ft/rad (Nm/rad)	30240 (41025)	56456 (76545)	– (–)	–
P	C	lb-ft/rad (Nm/rad)	– (41232)	– (80627)	– (132335)	– (188406)
U	C	lb-ft/rad (Nm/rad)	– (–)	– (–)	67180 (91093)	– (–)
K	C	lb-ft/rad (Nm/rad)	32270 (43950)	60352 (82112)	99448 (135303)	144680 (188406)
Moment of inertial rotary group	J_{TW}	lbs-ft ² (kgm ²)	0.0783 (0.0033)	0.1970 (0.0083)	0.3963 (0.0167)	0.5743 (0.0242)
Angular acceleration, maximum ²⁾	α	rad/s ²	4000	3300	2700	2700
Filling capacity	V	gal (L)	0.26(1.0)	0.4(1.6)	0.6(2.2)	0.8(3.0)
Weight (without through drive)	m	lbs (kg)	46(21)	73(33)	99(45)	132(60)

The values are applicable :

¹⁾- for an absolute pressure $p_{\text{abs}} = 15$ psi(1 bar) at suction port S

- within the optimum viscosity range from $v_{\text{opt}} = 80$ to 170 (16 to 36 mm²/s)
- for mineral-oil based hydraulic fluid.

²⁾ The scope of application lies between the minimum necessary and the maximum permissible drive speeds.
Valid for external excitation (e.g. diesel engine 2- to 8-fold rotary frequency, cardan shaft 2-fold rotary frequency)
The limiting value is only valid for a single pump.
The loading capacity of the connecting parts must be taken into account.

Note

Exceeding the maximum or falling below the minimum permissible values can lead to a loss of function, a reduction in operational service life or total destruction of the axial piston unit. We recommend to check the loading through tests or calculation / simulation and comparison with the permissible values.

Sizes 45, 71, 100 and 140 are optionally available in high-speed version.
External dimensions are not affected by this option.

Technical data

Permissible radial and axial loading on the drive shaft

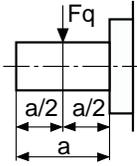
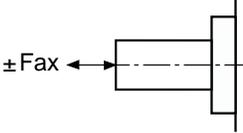
Size	NG	18	28	45	71	100	140
Radial force maximum at a/2		79 (350)	270 (1200)	337 (1500)	427 (1900)	517 (2300)	630 (2800)
Axial force maximum		157 (700)	225 (1000)	337 (1500)	540 (2400)	900 (4000)	1080 (4800)

Permissible input and through-drive torques

Size	NG	18	28	45	71	100	140
Torque	T_{max}	58(80)	91(125)	146(200)	230(316)	324(445)	453(623)
at $V_g \max$ and $\Delta p = 4000 \text{ psi (280 bar)}^1$							
Input torque for drive shaft, maximum ²⁾	$T_{E \max}$	92(124)	146(198)	235(319)	462(626)	814(1104)	1195(1620)
S	\emptyset	3/4	7/8	1	1 1/4	1 1/2	1 3/4
R	$T_{E \max}$	118(160)	184(250)	295(400)	475(644)	- (-)	- (-)
	\emptyset	3/4	7/8	1	1 1/4	-	-
P	$T_{E \max}$	- (88)	- (137)	- (200)	- (439)	- (857)	- (1206)
	\emptyset	18	22	25	32	40	45
U	$T_{E \max}$	43(59)	- (-)	- (-)	- (-)	439(595)	- (-)
	\emptyset	5/8	-	-	-	1 1/4	-
K	$T_{E \max}$	77(104)	107(145)	156(212)	319(433)	553(750)	875(1186)
	\emptyset	0.7500	0.8750	1.0000	1.2500	1.5000	1.7500
	(mm)	(19.05)	(22.225)	(25.4)	(31.75)	(38.1)	(44.45)
Maximum through-drive torque for drive shaft	$T_{D \max}$	80(108)	118(160)	235(319)	363(492)	574(778)	934(1266)
S	$T_{D \max}$	88(120)	130(176)	269(365)	404(548)	- (-)	- (-)
R	$T_{D \max}$	- (88)	- (137)	- (200)	- (439)	- (778)	- (1206)
P	$T_{D \max}$	77(104)	107(145)	156(212)	319(433)	553(750)	875(1186)
K	$T_{D \max}$	80(108)	118(160)	235(319)	363(492)	574(778)	934(1266)

¹⁾ Without considering efficiency

²⁾ For drive shafts free of radial load

Distribution of torques

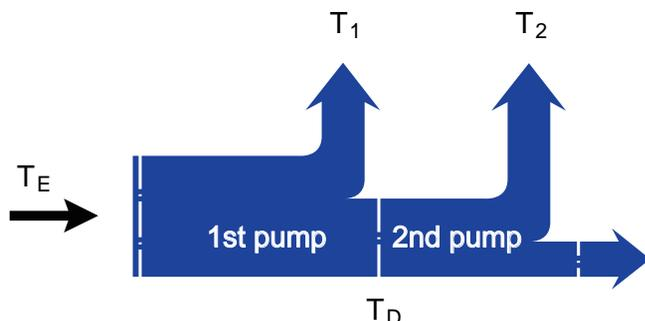

Technical data

Drive power

Working position :

Flow ISO VG 46 DIN 51519 · t = 50 °C

A

8

PA10VSO

size 18

--- n = 1500 rpm
 _____ n = 3300 rpm

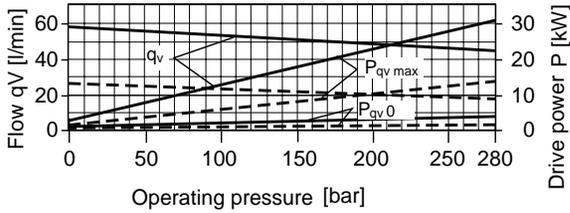

size 28

--- n = 1500 rpm
 _____ n = 3000 rpm

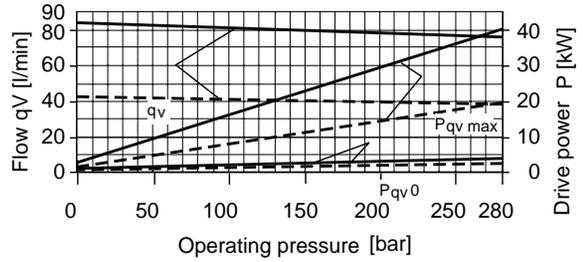

size 45

--- n = 1500 rpm
 _____ n = 2600 rpm

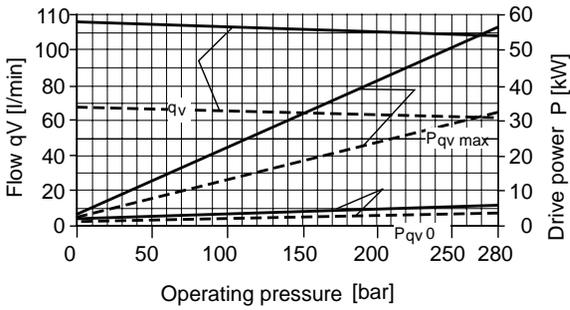

size 71

--- n = 1500 rpm
 _____ n = 2200 rpm

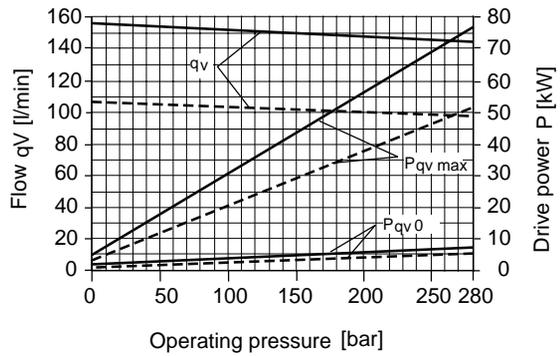

size 100

--- n = 1500 rpm
 _____ n = 2000 rpm

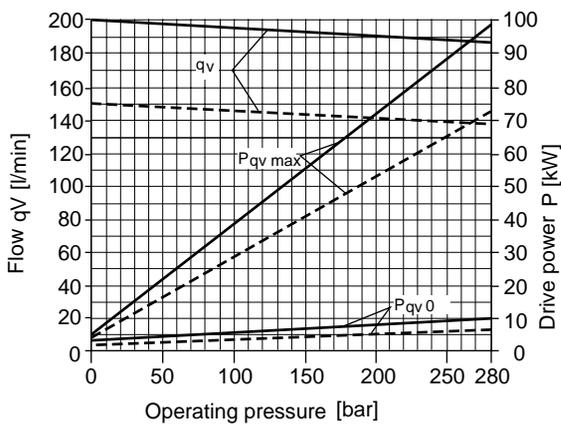

size 140

--- n = 1500 rpm
 _____ n = 1800 rpm

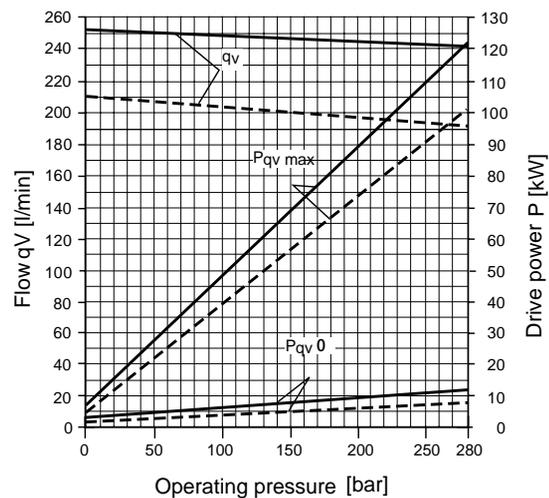

DG — Two-point control, directly operated

The variable pump can be set to a minimum swivel angle by connecting an external control pressure to port X.

This will supply control fluid directly to the stroke piston; a minimum control pressure of $p_{st} \geq 725$ psi (50 bar) is required. °

The variable pump can only be switched between $V_{g \max}$ or $V_{g \min}$ °

Please note, that the required control pressure at port X is directly dependent on the actual operating pressure p_B in port B. (See control pressure characteristic).

Control pressure $p_{st} = 0$ psi (0 bar) $\hat{=}$ $V_{g \max}$
 Control pressure $p_{st} \geq 725$ psi (50 bar) $\hat{=}$ $V_{g \min}$

Control pressure characteristic

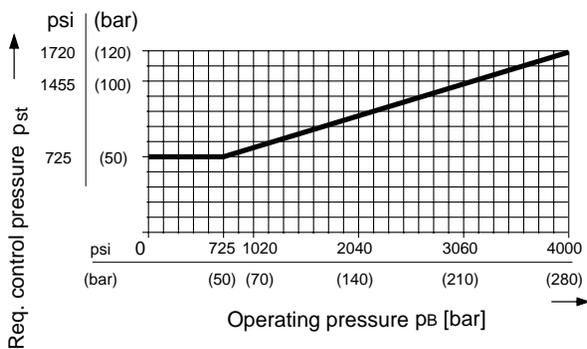

Circuit diagram

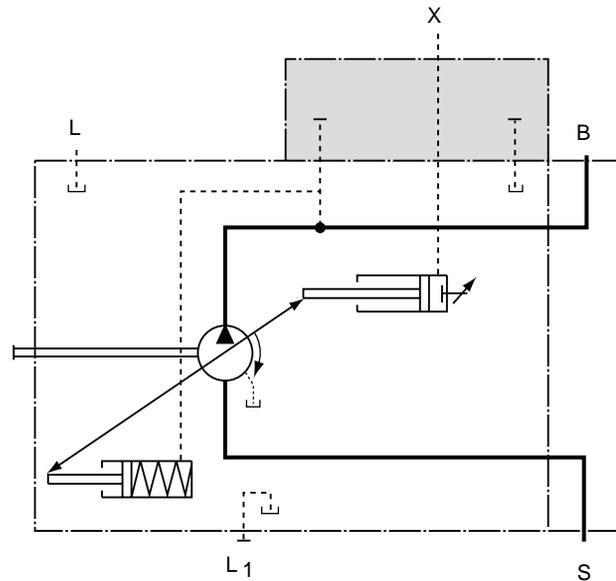

	Port for
B	Service line
S	Suction line
L · L1	Case drain(L1 plugged)
X	Pilot pressure

DR — Pressure control

A

10

PA10VSO

The pressure control limits the maximum pressure at the pump output within the pump control range. The variable pump only supplies as much hydraulic fluid as is required by the consumers. If the operating pressure exceeds the pressure setpoint set at the integrated pressure valve, the pump will adjust towards a smaller displacement and the control deviation will be reduced. The pressure can be set steplessly at the control valve.

Static characteristic

(at $n_1 = 1800 \text{ rpm}$; $t_{\text{fluid}} = 122^\circ\text{F}$ (50°C)

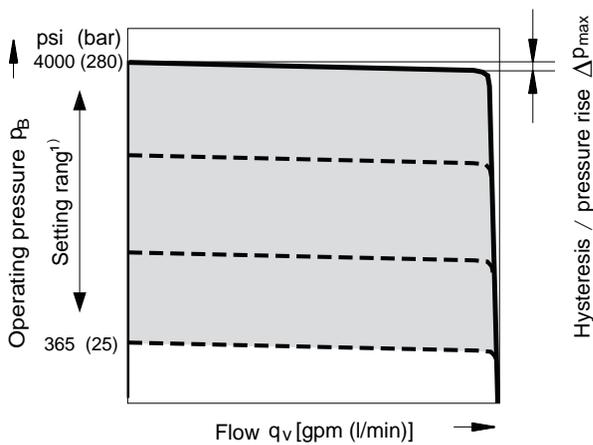

¹⁾In order to prevent damage to the pump and the system, this setting range is the permissible setting range and must not be exceeded. The range of possible settings at the valve are greater.

Circuit diagram, sizes 18 to 100

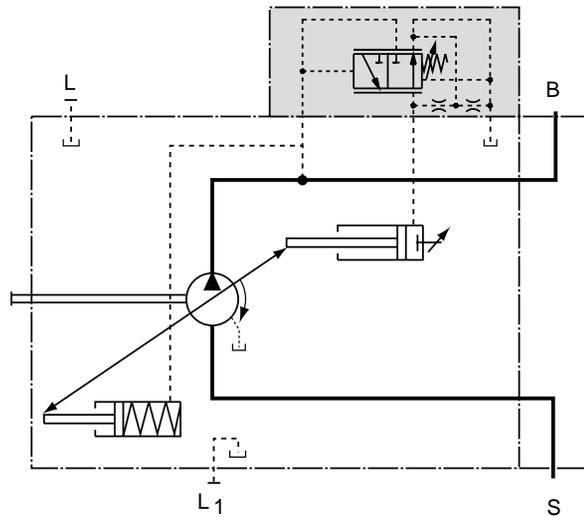

Circuit diagram, size 140

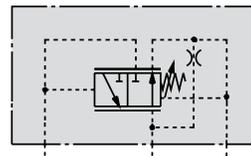

	Port for
B	Service line
S	Suction line
L、L1	Case drain(L1 plugged)

Control data

Hysteresis and repeatability Δp_{max} approx. 3 bar

Pressure rise, maximum

NG	18	28	45	71	100	140
Δp psi	60	60	90	8	115	175
(bar)	(4)	(4)	(6)	(8)	(10)	(12)

Contr. fluid consum. max. approx. 0.8 gpm (3 l/min)
please following page A-8

DRG — Pressure control, remotely operated

A pressuer relief valve can be externally piped to por X for remote setting of pressure below the setting of the DR control valve spool. This relief valve is not included in the delivery contents of the DRG control.

The differential pressure at the DRG control valve is set as standard to 290 psi (20 bar). This results in a pilot oil fiow to the relief valve of approx.0.4 gpm (1.5 l/min) at port X. If another setting is required (range from 145 to 320 psi (10-22 bar)) please state in clear text.

The max.length of piping should not exceed 6.6 ft (2m).

Static characteristic

(at $n_1 = 1800$ rpm ; $t_{fluid} = 122^\circ\text{F}$ (50 °C))

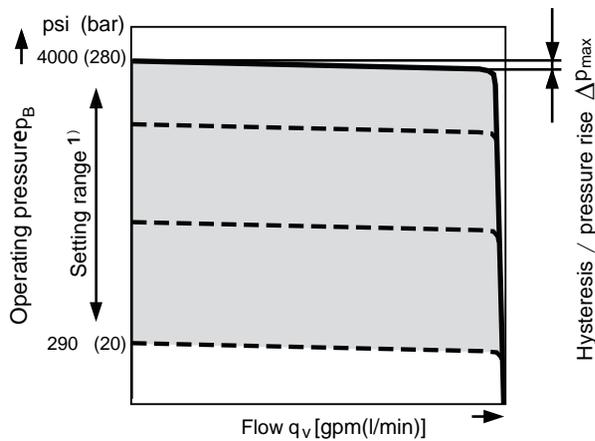

1) In order to prevent damage to the pump and the system, this setting range is the permissible setting range and must not be exceeded.

The range of possible settings at the valve are greater.

Circuit diagram, sizes 18 to 100

Not included in the delivery contents

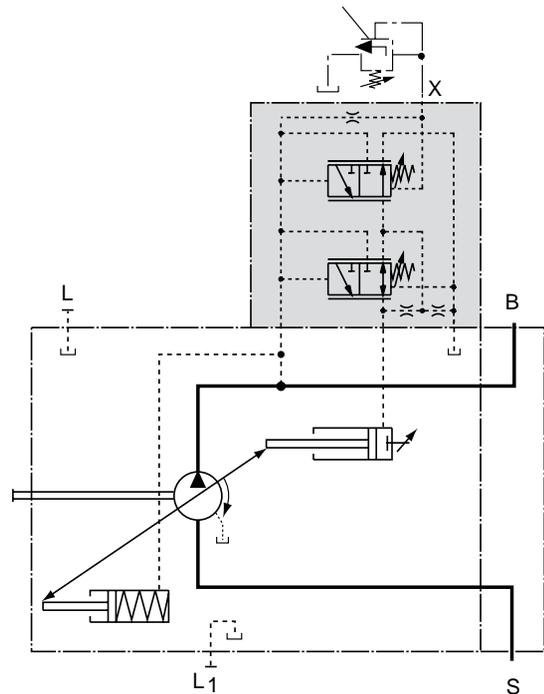

Circuit diagram, size 140

Not included in the delivery contents

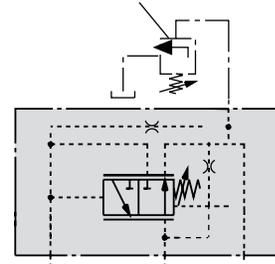

		Port for
B		Service line
S		Suction line
L · L1		Case drain (L1 plugged)
X	NG 18 to 100 without adapter	Pilot pressure
X	NG 140 with adapter	Pilot pressure

Control data

Hysteresis and repeatability Δp_{max} approx. 45 psi (3 bar)

Pressure rise, maximum

NG	18	28	45	71	100	140
Δp psi (bar)	60 (4)	60 (4)	90 (6)	115 (8)	145 (10)	175 (12)

Contr. fluid consum__max. approx. 1.2 gpm (4.5 l/min) please following page A-8

DFR/DFR1 — Pressure and flow control

A

12

PA10VSO

In addition to the pressure control function, the pump flow may be varied by means of a differential pressure over an adjustable orifice (e.g. directional valve) installed in the service line to the actuator. The pump flow is equal to the actual required flow by the actuator, regardless of changing pressure levels.

The pressure control overrides the flow control function.

Note

The DFR1 version has no connection between X and the reservoir. Unloading the LS-pilot line must be possible in the valve system. Because of the flushing function sufficient unloading of the X-line must also be provided.

Static characteristic

Flow control at $n_1 = 1500 \text{ rpm}$; $t_{\text{fluid}} = 122^\circ\text{F} (50^\circ\text{C})$

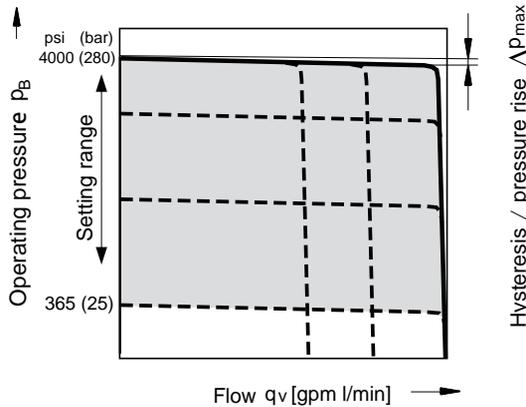

1) In order to prevent damage to the pump and the system, this setting range is the permissible setting range and must not be exceeded. The range of possible settings at the valve are greater.

Static characteristic at variable speed

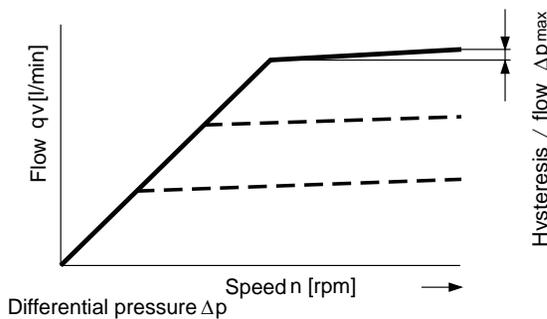

Standard setting : 200 to 320 psi (14 to 22 bar).
If another setting is required, please state in clear text. Relieving the load on port X to the reservoir results in a zero stroke ("standby") pressure which lies about 15 to 30 psi (1 to 2 bar) higher than the differential pressure Δp . System influences are not taken into account.

Circuit diagram, sizes 18 to 100

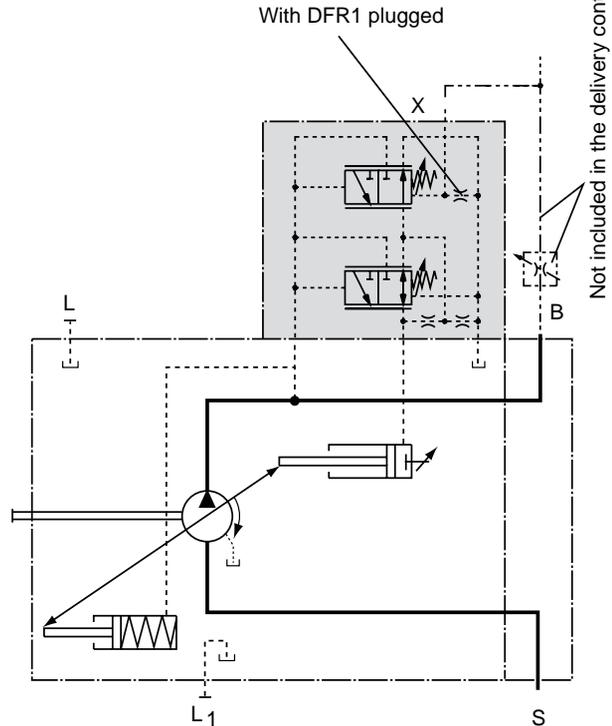

Circuit diagram, size 140

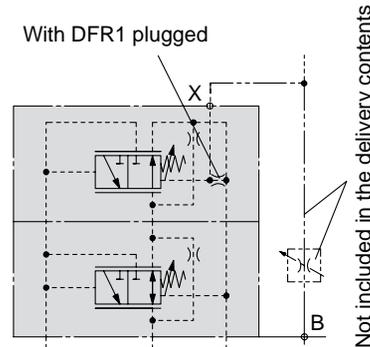

	Port for
B	Service line
S	Suction line
L · L1	Case drain (L1 plugged)
X	Pilot pressure

Control data

Data for pressure control DR, please see following page A-10. Maximum flow deviation measured at drive speed $n = 1500 \text{ rpm}$.

NG	18	28	45	71	100	140
$\Delta q_v \text{ max}$ gpm	0.24	0.26	0.48	0.75	1.06	1.60
l/min	(0.9)	(1.0)	(1.8)	(2.8)	(4.0)	(6.0)

Contr fluid consum. DFR __max.approx. 0.8 to 1.2 gpm (3 to 4.5 l/min)

Contr fluid consum. DFR1 __max.approx 0.8 gpm(3 l/min) please following page A-8

DFLR — Pressure, flow and power control

Execution of the pressure control like,DR(G),please following page A-10(11).
 Execution of the flow control like DFR,DFR1,please following page A-12.

In order to achieve a constant drive torque with varying operating pressures, the swivel angle and with it the output flow from the axial piston pump is varied so that the product of flow and pressure remains constant.

Flow control is possible below the power control curve.

Static curves and torque characteristic

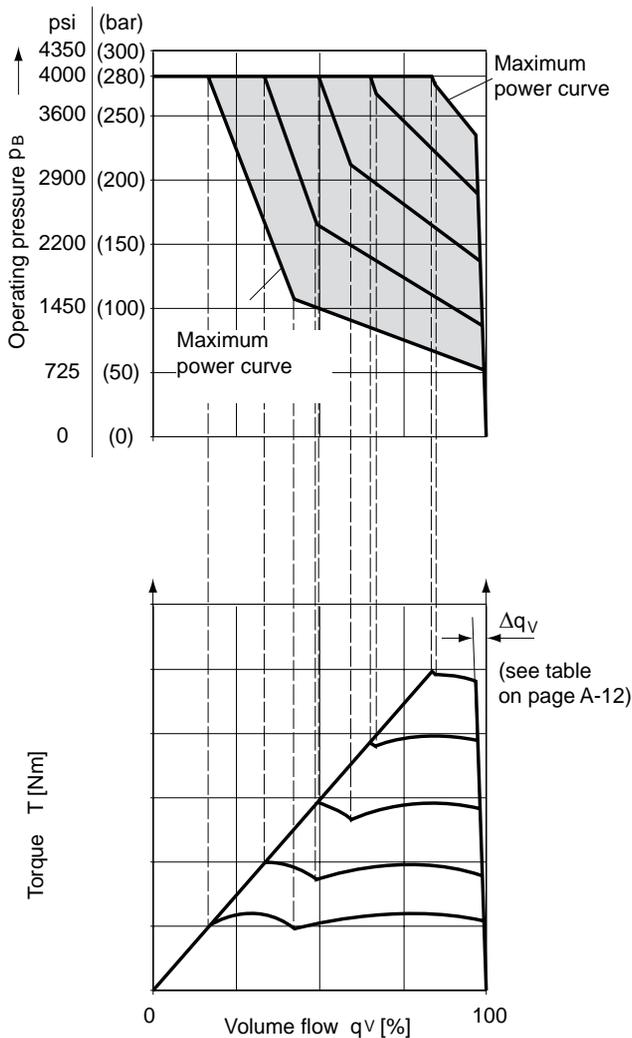

Control data

Beginning of control _____ 735 psi (50 bar)
 Control fluid consumption_max.approx. 1.45 gpm (5.5 l/min)
 please following page A-8

	Port for
B	Service line
S	Suction line
L · L ₁	Case drain (L ₁ plugged)
X	Pilot pressure

The power characteristic is set in the factory; when ordering,please state in clear text, e.g. 27HP (20 kW) at 1800 rpm

Control data

For pressure control DR data,please following page A-10.

For flow control DFR / DFR1 data,please following page A-12.

Circuit diagram, sizes 28 to 100

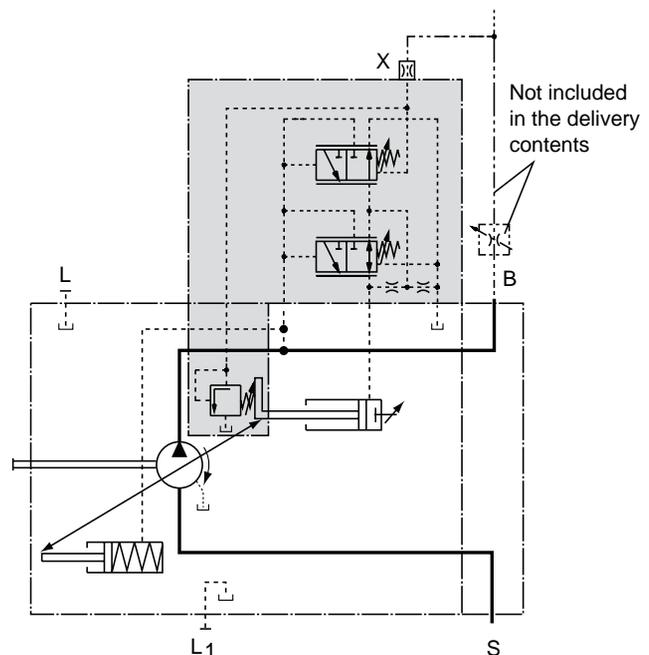

Circuit diagram, size 140

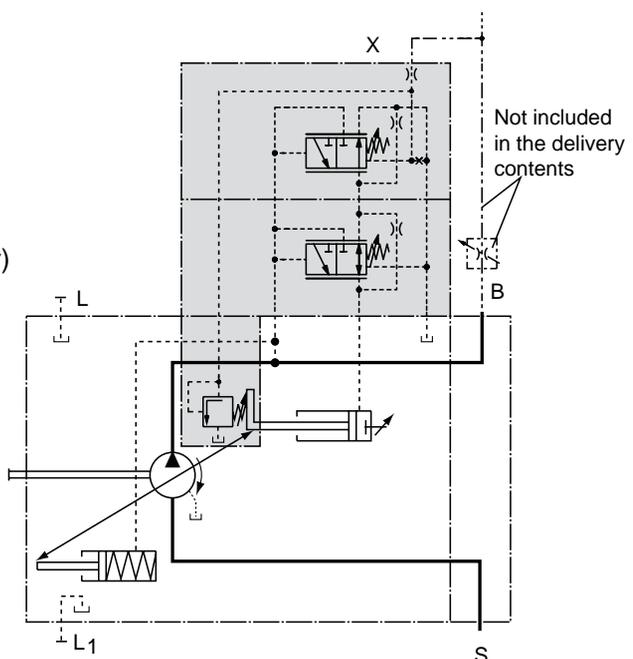

ED — Electro-hydraulic pressure control

A

14

PA10VSO

The ED valve is set to a certain pressure by a specified, variable solenoid current.

If there is a change at the consumer (load pressure), the position of the control piston changes. This causes an increase or decrease in the pump swivel angle (flow) in order to maintain the electrically set pressure level.

The pump thus only delivers as much hydraulic fluid as the consumers can take. The desired pressure level can be set steplessly by varying the solenoid current.

When the solenoid current signal drops towards a zero value, the maximum output pressure is limited to p_{max} by an adjustable hydraulic pressure cut-off (secure fail safe function in case of a loss of power e.g. for use as fan drives).

The response time characteristic of the ED-control was optimized for the use as a fan drive system.

When ordering, state the type of application in clear text.

Static current-pressure characteristic ED

(measured at pump in zero stroke – negative characteristic)

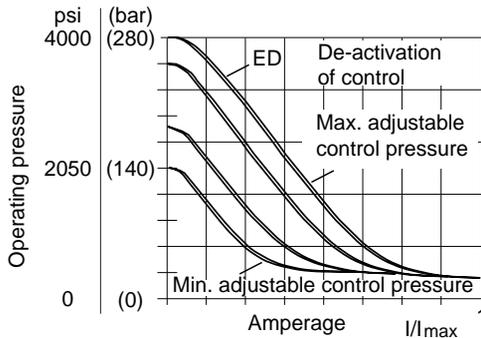

Hysteresis static current-press. characteristic < 45 psi 3 bar

Static flow-pressure characteristic

(at $n_1 = 1800 \text{ rpm}$; $t_{fluid} = 122^\circ\text{F}$ (50°C))

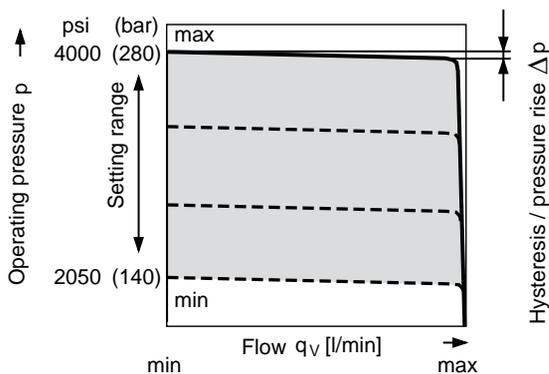

Control data

Stand-by standard setting 290 psi (20 bar), other values on request.

Hysteresis and pressure rise $\Delta p < 60 \text{ psi}$ (4 bar)

Control fluid consumption $0.8 \text{ to } 1.2 \text{ gpm}$ (3 to 4.5 l/min)

Influence of pressure setting on standby level

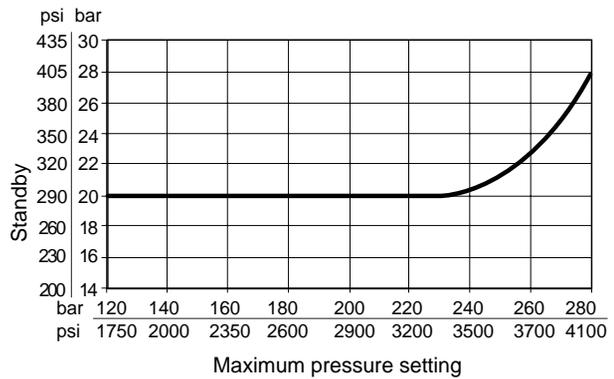

Circuit diagram ED..

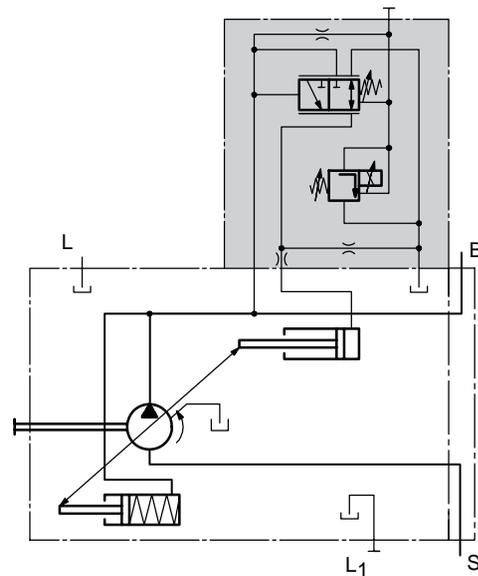

	Port for
B	Service line
S	Suction line
L \ L1	Case drain (L1 plugged)

Technical data, solenoid	ED71	ED72
Voltage	12 V(±20 %)	24 V(±20%)
Control current		
Control begin at $q_{v \text{ min}}$	100 mA	50 mA
End of control at $q_{v \text{ max}}$	1200 mA	600 mA
Limiting current	1.54 A	0.77 A
Nominal resistance (at 68°F (20°C))	5.5 Ω	22.7 Ω
Dither frequency	100 to 200 Hz	100 to 200 Hz
Actuated time	100 %	100 %

For type of protection, Please contact YEOSHE.
For details on the control electronics, following page A-15.

Operating temperature range at valve -4°F to 239°F (-20°C to $+115^\circ\text{C}$)

ER — Electro-hydraulic pressure control

The ER valve is set to a specific pressure by a specified, variable solenoid current.

If there is a change at the consumer (load pressure), the position of the control piston changes.

This causes an increase or decrease in the pump swivel angle (flow) in order to maintain the electrically set pressure level. The pump thus only delivers as much hydraulic fluid as the consumers can take. The desired pressure level can be set steplessly by varying the solenoid current.

If the solenoid current drops to zero, the pressure is limited to p_{min} (stand-by).

Observe the project planning note on page A-1.

Static current-pressure characteristic ER

(measured at pump in zero stroke – positive characteristic)

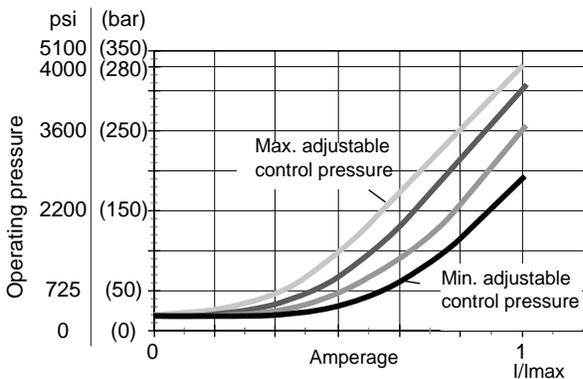

Hysteresis static current-press. characteristic < 45 psi (3 bar)
Influence of pressure setting on stand-by ± 30 psi (± 2 bar)

Static flow-pressure characteristic

(at $n = 1800$ rpm; $t_{fluid} = 122^\circ\text{F}$ (50°C))

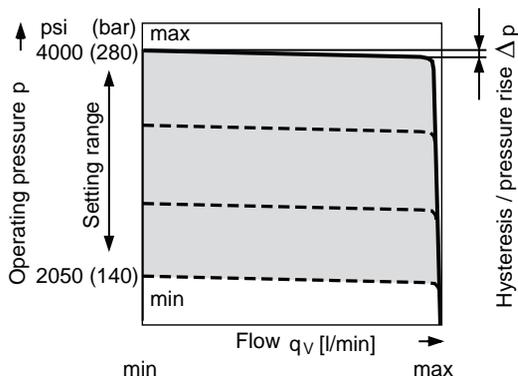

Control data

Standby standard setting 290 psi (20 bar), other values on request.

Hysteresis and pressure increase $\Delta p < 60$ psi (4 bar)
Control fluid consumption 0.8 to 1.2 gpm (3 to 4.5 l/min)

Circuit diagram ER..

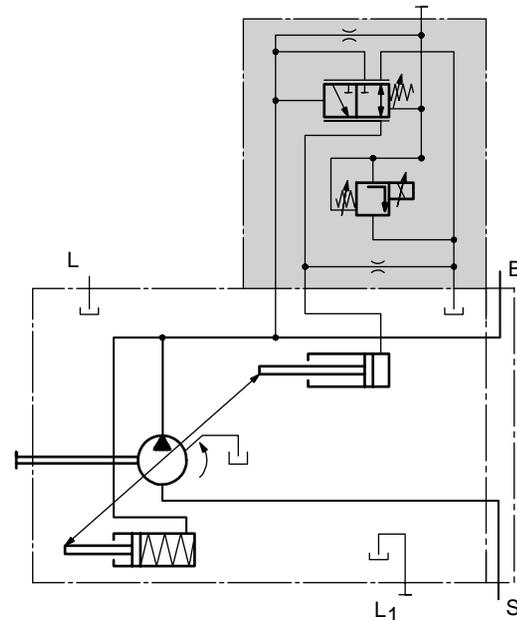

	Port for
B	Service line
S	Suction line
L · L1	Case drain (L1 plugged)

Technical data, solenoid	ER71	ER72
Voltage	12 V ($\pm 20\%$)	24 V ($\pm 20\%$)
Control current		
Control begin at $q_{v\ min}$	100 mA	50 mA
End of control at $q_{v\ max}$	1200 mA	600 mA
Limiting current	1.54 A	0.77 A
Nominal resistance 20°C	5.5 Ω	22.7 Ω
Dither frequency	100 to 200 Hz	100 to 200 Hz
Actuated time	100 %	100 %

For type of protection, Please contact YEOSHE.

Operating temperature range at valve -4°F to 239°F (-20°C to $+115^\circ\text{C}$)

The following electric controllers and amplifiers are available for controlling the proportional solenoids

- 1) Power outlets for 2 valves, can be actuated separately
- 2) Only 24V nominal voltage

Dimensions size 18

DFR, DFR1 – Pressure and flow control, hydraulic
Clockwise rotation

Before finalizing your design request a certified installation drawing.
Dimensions in (mm).

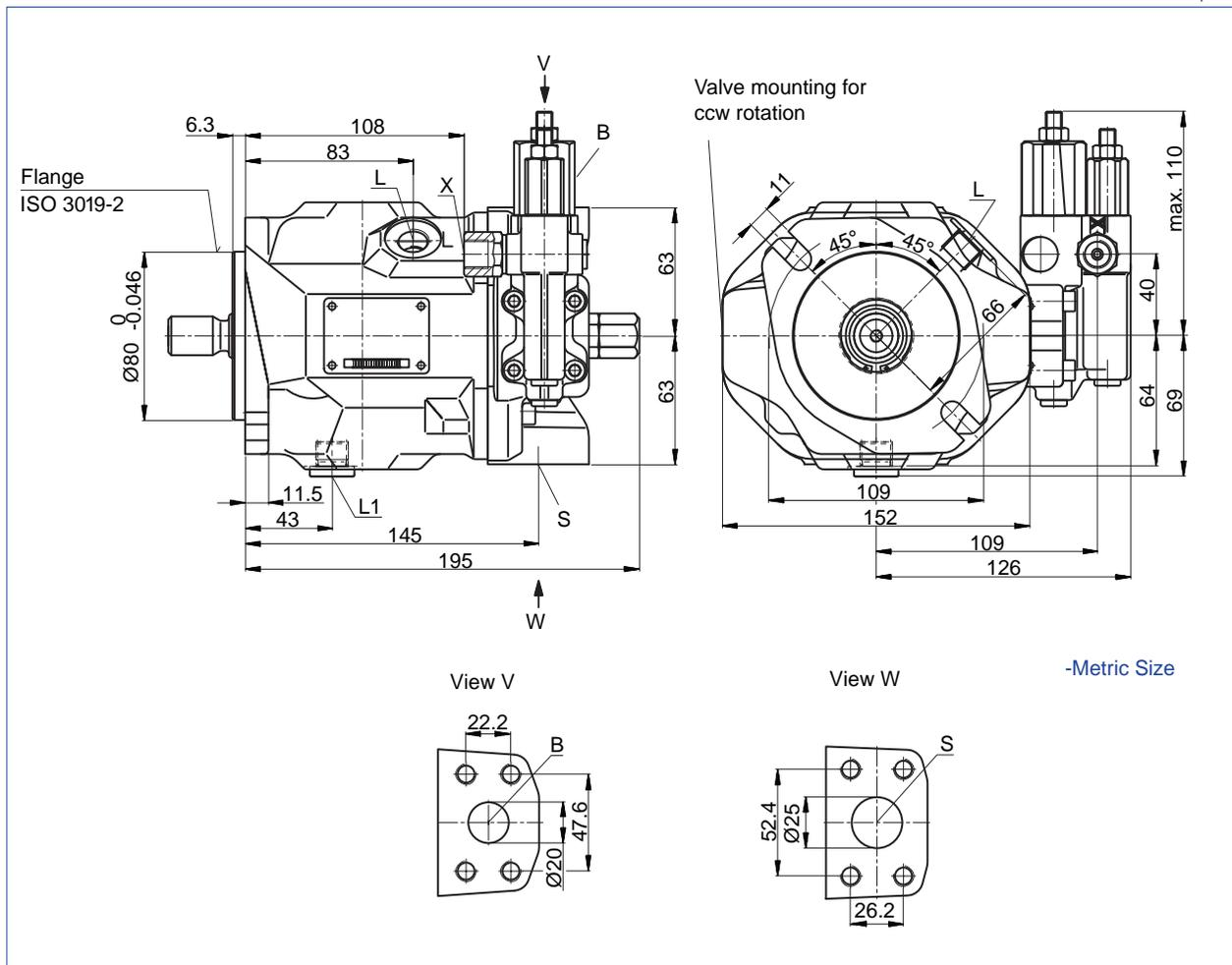

Ports

Designation	Port for	Standard	Size ¹⁾	Maximum pressure[psi(bar)] ²⁾	State
B	Service line, fastening thread	SAE J518 ³⁾ DIN 13	3/4 in M10 x 1.5 : 17 (deep)	5100(350)	O
S	Suction line, fastening thread	SAE J518 ³⁾ DIN 13	1 in M10 x 1.5 : 17 (deep)	145(10)	O
L	Case drain fluid	DIN 3852 ⁴⁾	M16 x 1.5 : 12 (deep)	30(2)	O ⁵⁾
L1	Case drain fluid	DIN 3852 ⁴⁾	M16 x 1.5 : 12 (deep)	30(2)	X ⁵⁾
X	Pilot pressure	DIN 3852 ⁴⁾	M14 x 1.5 : 12 (deep)	5100(350)	O
X	Pilot press. with DG-control	DIN ISO 228 ⁴⁾	G 1/4 in	5100(350)	O

- 1) For the maximum tightening torques the general instructions on page A-64 must be observed.
- 2) Depending on the application, short-term pressure spikes can occur. Keep this in mind when selecting measuring equipment and fittings. Pressure values in bar absolute.
- 3) The dimension follow SAE J518, Metric fastening thread and standard thread are different.
- 4) The spot face can be deeper than as specified in the standard.
- 5) Depending on the installation position, L or L1 must be connected (the following page A-62 \ A-63, please check assembling instruction.)
O = Must be connected (plugged on delivery)
X = Plugged (in normal operation)

Dimensions size 18

Before finalizing your design request a certified installation drawing. Dimensions in (mm).

Drive shaft

S Splined shaft 3/4 in 11T 16/32DP¹⁾ (SAE J744)

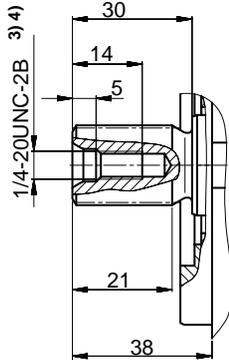

R Splined shaft 3/4 in 11T 16/32DP¹⁾²⁾ (SAE J744)

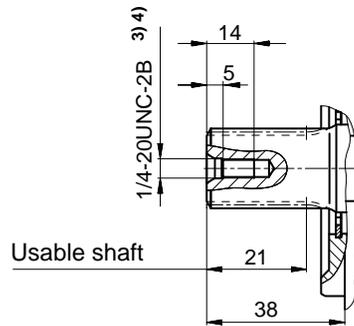

P Parallel shaft key DIN 6885 · A6x6x25

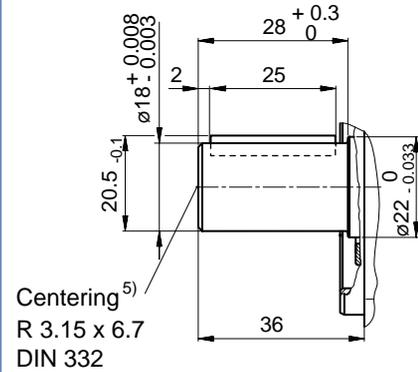

U Splined shaft 5/8 in 9T 16/32DP¹⁾²⁾ (SAE J744)

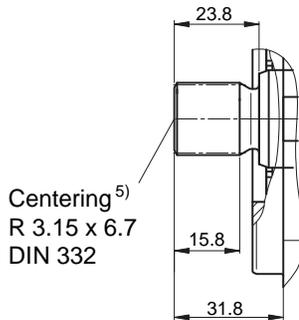

- 1) ANSI B92.1a · 30° pressure angle, flat root, side fit, tolerance class 5
- 2) Splines according to ANSI B92.1a, run out of spline is a deviation from standard
- 3) Thread according to ASME B1.1
- 4) For the maximum tightening torques the general instructions on page A-64 must be observed
- 5) Coupling axially secured, e.g. with a clamp coupling or radially mounted clamping screw

Dimensions size 18

A

18

PA10VSO - Metric Size

Before finalizing your design request a certified installation drawing. Dimensions in (mm).

DG
Two-point control, directly operated

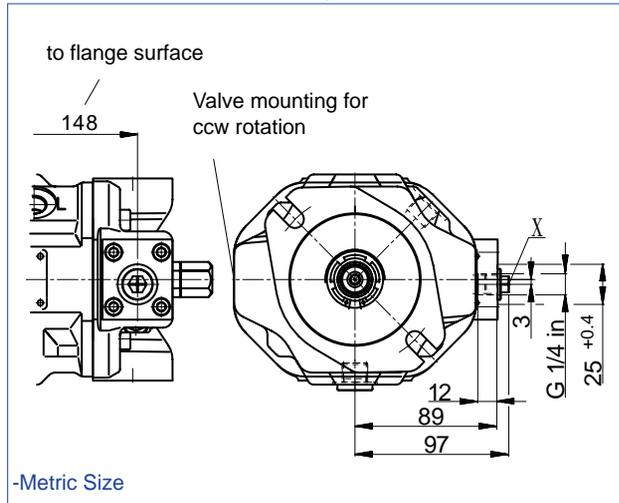

DR
Pressure control

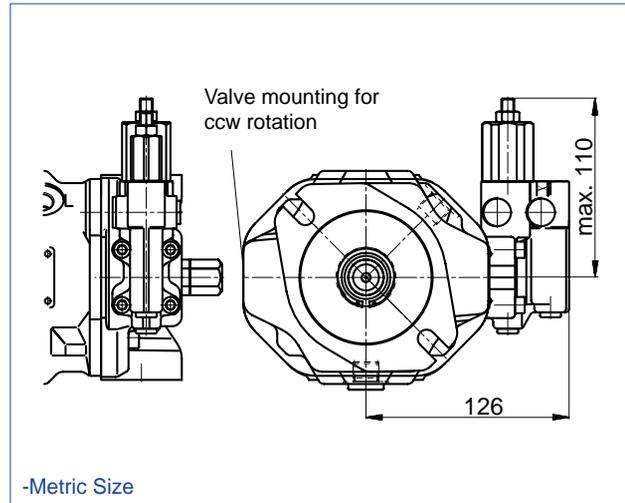

DRG
Pressure control, remotely operated

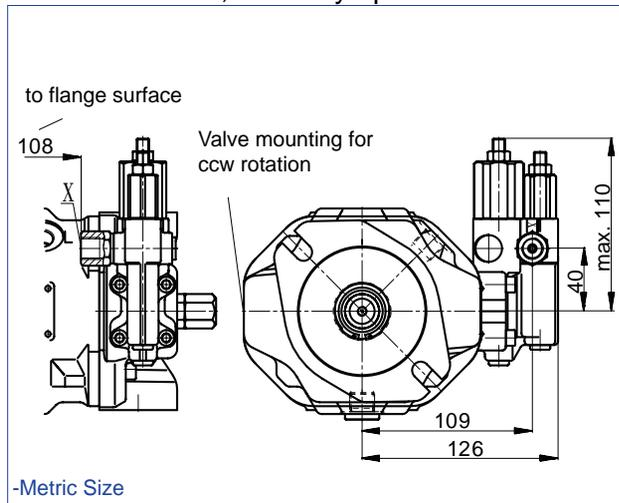

ED7., ER7.
Electro-hydraulic pressure control

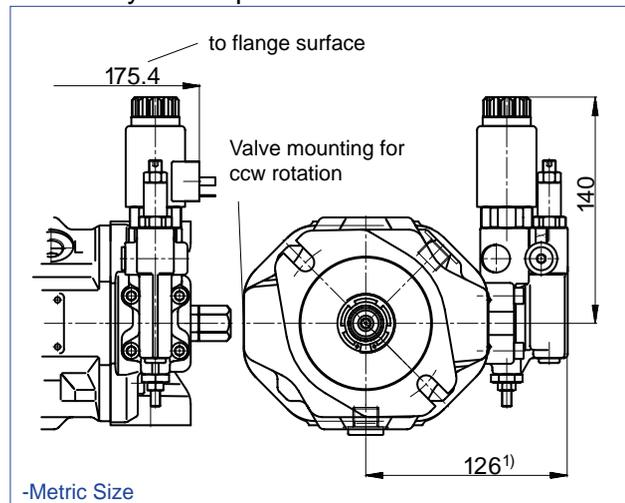

¹⁾ ER7.: 161 mm if using a sandwich plate pressure reducing valve.

Dimensions size 28

DFR/DFR1 – Pressure and flow control, hydraulic
 Clockwise rotation

Before finalizing your design request a certified installation drawing. Dimensions in (mm).

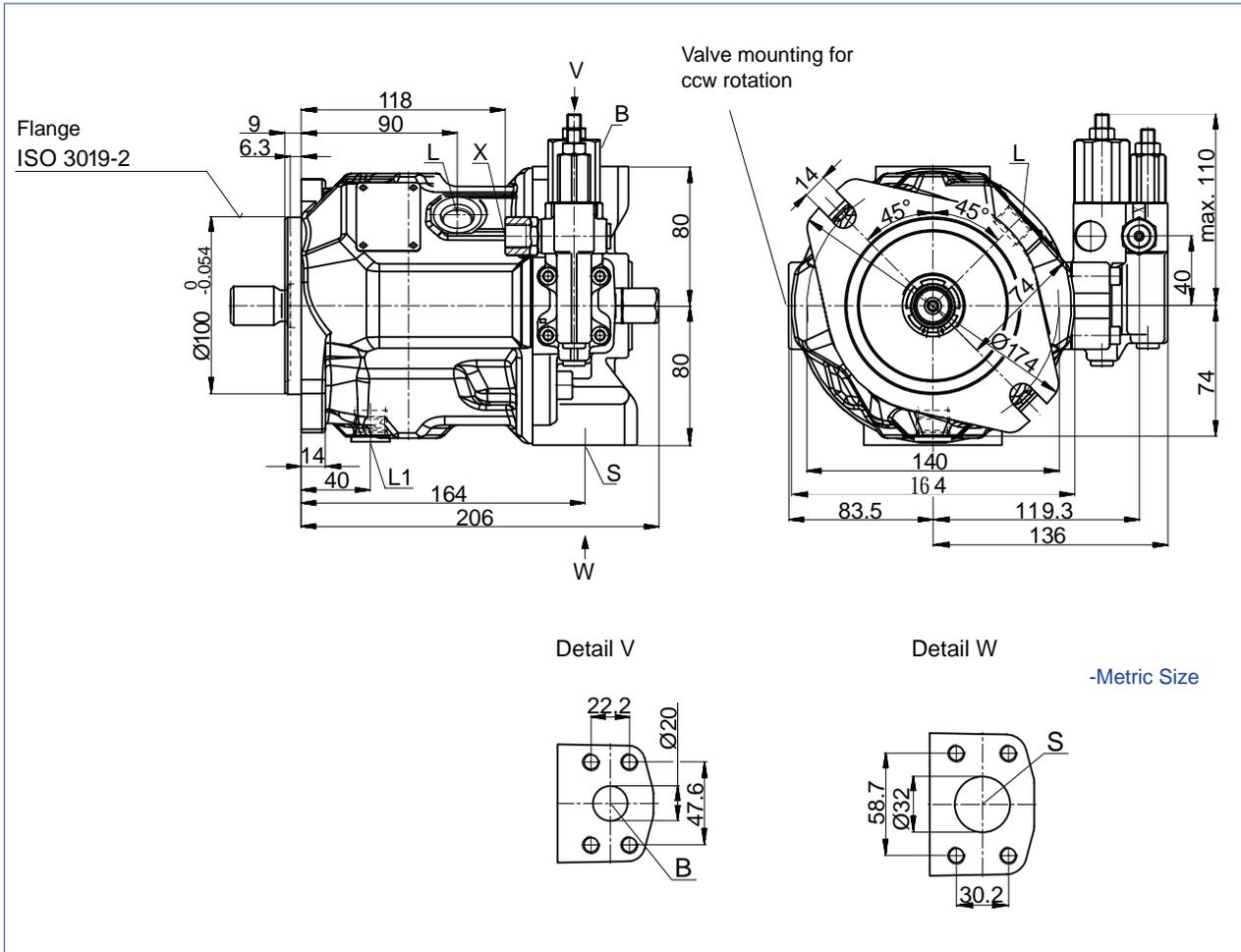

Ports

Designation	Port for	Standard	Size ¹⁾	Maximum pressure[psi(bar)] ²⁾	State
B	Service line, fastening thread	SAE J518 ³⁾ DIN 13	3/4 in M10 x 1.5 : 17 (deep)	5100(350)	O
S	Suction line, fastening thread	SAE J518 ³⁾ DIN 13	1 1/4in M10 x 1.5 : 17 (deep)	145(10)	O
L	Case drain fluid	DIN 3852 ⁴⁾	M18 x 1.5 : 12 (deep)	30(2)	O ⁵⁾
L ₁	Case drain fluid	DIN 3852 ⁴⁾	M18 x 1.5 : 12 (deep)	30(2)	X ⁵⁾
X	Pilot pressure	DIN 3852 ⁴⁾	M14 x 1.5 : 12 (deep)	5100(350)	O
X	Pilot press. with DG-control	DIN ISO 228 ⁴⁾	G 1/4 in : 12 (deep)	5100(350)	O

- 1) For the maximum tightening torques the general instructions on page A-64 must be observed.
- 2) Depending on the application, short-term pressure spikes can occur. Keep this in mind when selecting measuring equipment and fittings. Pressure values in bar absolute.
- 3) The dimension follow SAE J518, Metric fastening thread and standard thread are different.
- 4) The spot face can be deeper than as specified in the standard.
- 5) Depending on the installation position, L or L₁ must be connected (the following page A-62 \ A-63, please check assembling instruction.)
 O = Must be connected (plugged on delivery)
 X = Plugged (in normal operation)

Dimensions size 28

Before finalizing your design request a certified installation drawing. Dimensions in (mm).

Drive shaft

S Splined shaft 7/8 in 13T 16/32DP¹⁾ (SAE J744)

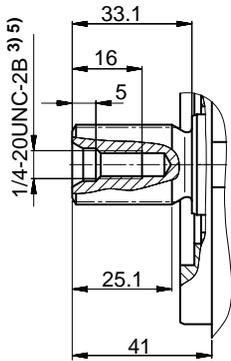

R Splined shaft 7/8 in 13T 16/32DP¹⁾²⁾ (SAE J744)

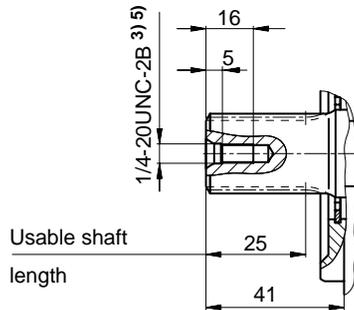

P Parallel shaft key DIN 6885 · A6x6x32

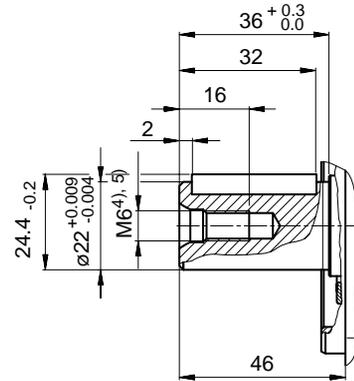

U Splined shaft 3/4 in 11T 16/32DP¹⁾ (SAE J744)

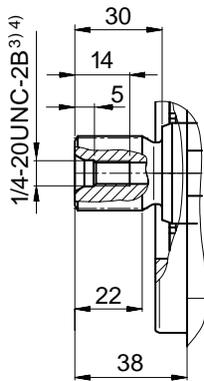

W Splined shaft 3/4 in 11T 16/32DP¹⁾²⁾ (SAE J744)

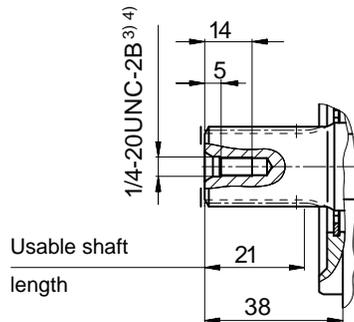

- 1) ANSI B92.1a · 30° pressure angle, flat root, side fit, tolerance class 5
- 2) Splines according to ANSI B92.1a, run out of spline is a deviation from standard
- 3) Thread according to ASME B1.1
- 4) Thread according to DIN 13
- 5) For the maximum tightening torques the general instructions on page A-64 must be observed.

Dimensions size 28

Before finalizing your design request a certified installation drawing. Dimensions in (mm).

DG
Two-point control, directly operated

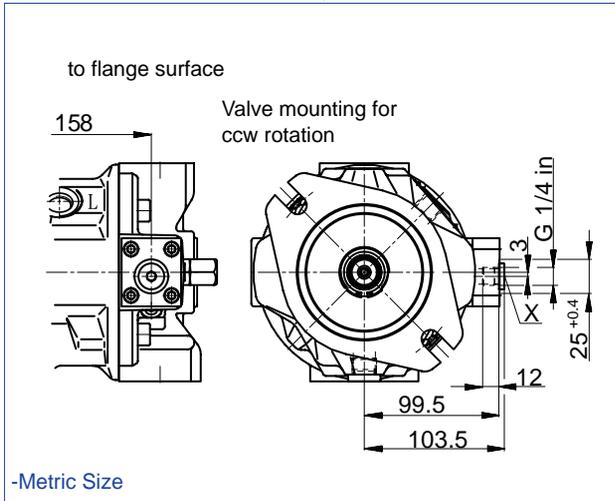

DFLR
Pressure, flow and power control

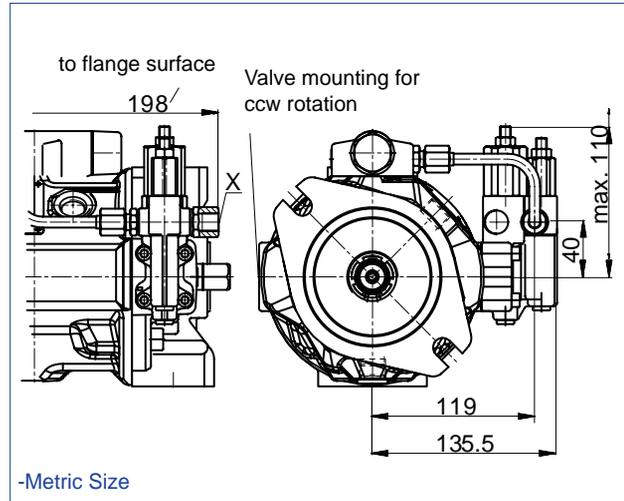

DR
Pressure control

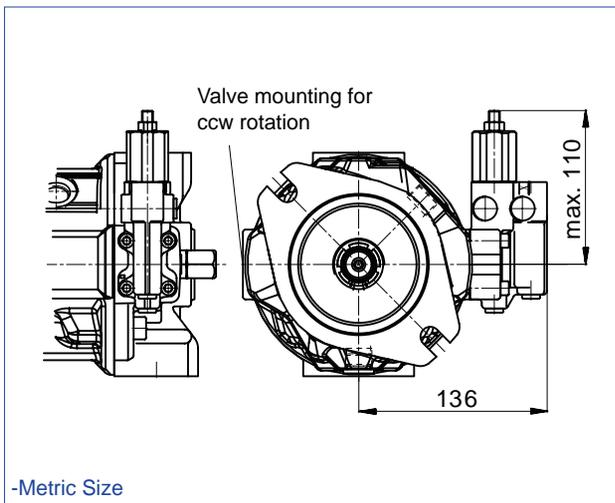

DRG
Pressure control, remotely operated

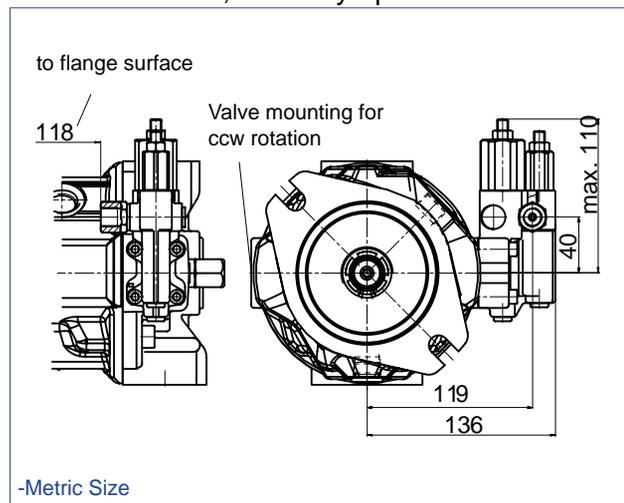

ED7. / ER7.
Electro-hydraulic pressure control

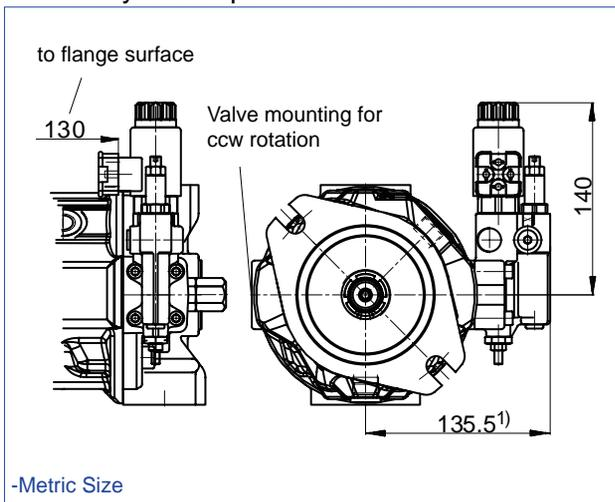

¹) ER7.: 170.5 mm when using a sandwich plate pressure reducing valve.

For details of connection options and drive shafts, see also page A-19 and A-20.

Dimensions size 45

DFR/DFR1 – Pressure and flow control, hydraulic
Clockwise rotation

Before finalizing your design request a certified installation drawing. Dimensions in (mm).

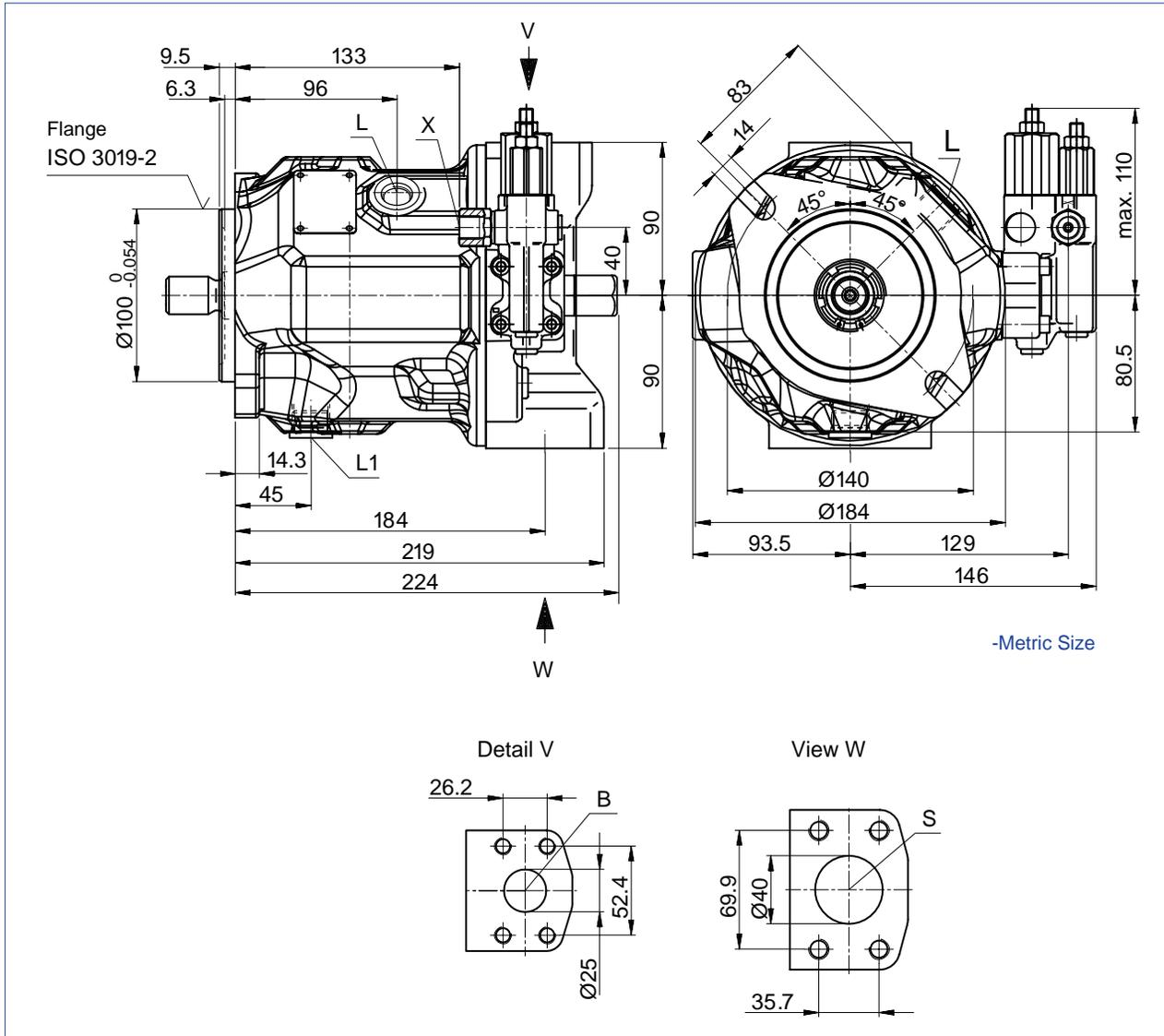

Ports

Designation	Port for	Standard	Size ¹⁾	Maximum pressure[psi(bar)] ²⁾	State
B	Service line, fastening thread	SAE J518 ³⁾ DIN 13	1 in M10 x 1.5 : 17 (deep)	5100(350)	O
S	Suction line, fastening thread	SAE J518 ³⁾ DIN 13	1 1/2in M12 x 1.75 : 20 (deep)	145(10)	O
L	Case drain fluid	DIN 3852 ⁴⁾	M22 x 1.5 : 14 (deep)	30(2)	O ⁵⁾
L ₁	Case drain fluid	DIN 3852 ⁴⁾	M22 x 1.5 : 14 (deep)	30(2)	X ⁵⁾
X	Pilot pressure	DIN 3852 ⁴⁾	M14 x 1.5 : 12 (deep)	5100(350)	O
X	Pilot press. with DG-control	DIN ISO 228 ⁴⁾	G 1/4 in	5100(350)	O

- 1) For the maximum tightening torques the general instructions on page A-64 must be observed.
- 2) Depending on the application, short-term pressure spikes can occur. Keep this in mind when selecting measuring equipment and fittings. Pressure values in bar absolute.
- 3) The dimension follow SAE J518, Metric fastening thread and standard thread are different.
- 4) The spot face can be deeper than as specified in the standard
- 5) Depending on the installation position, L or L₁ must be connected (the following page A-62 \ A-63, please check assembling instruction.)
O = Must be connected (plugged on delivery)
X = Plugged (in normal operation)

Dimensions size 45

Before finalizing your design request a certified installation drawing. Dimensions in (mm).

Drive shaft

S Splined shaft 1 in 15T 16/32DP¹⁾ (SAE J744)

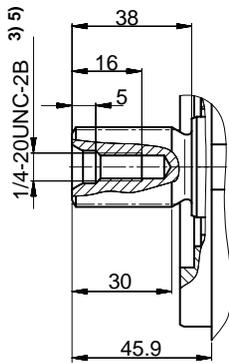

R Splined shaft 1 in 15T 16/32DP¹⁾²⁾ (SAE J744)

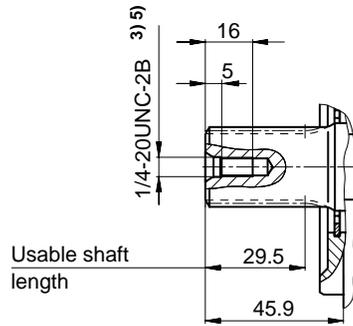

P Parallel shaft key DIN 6885 · A8x7x36

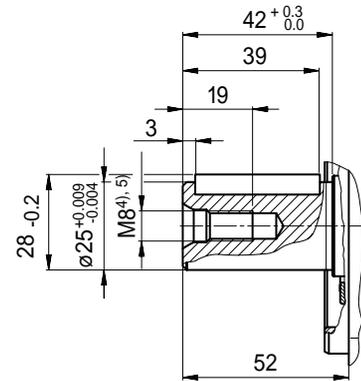

U Splined shaft 7/8 in 13T 16/32DP¹⁾ (SAE J744)

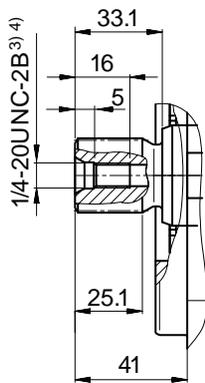

W Splined shaft 7/8 in 13T 16/32DP¹⁾²⁾ (SAE J744)

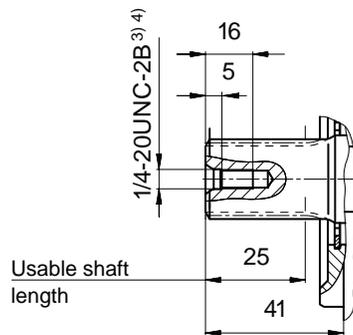

- ¹⁾ ANSI B92.1a · 30° pressure angle, flat root, side fit, tolerance class 5
- ²⁾ Splines according to ANSI B92.1a, run out of spline is a deviation from standard
- ³⁾ Thread according to ASME B1.1
- ⁴⁾ Thread according to DIN 13
- ⁵⁾ For the maximum tightening torques the general instructions on page A-64 must be observed.

Dimensions size 45

A

24

PA10VSO - Metric Size

Before finalizing your design request a certified installation drawing. Dimensions in (mm).

DG
Two-point control, directly operated

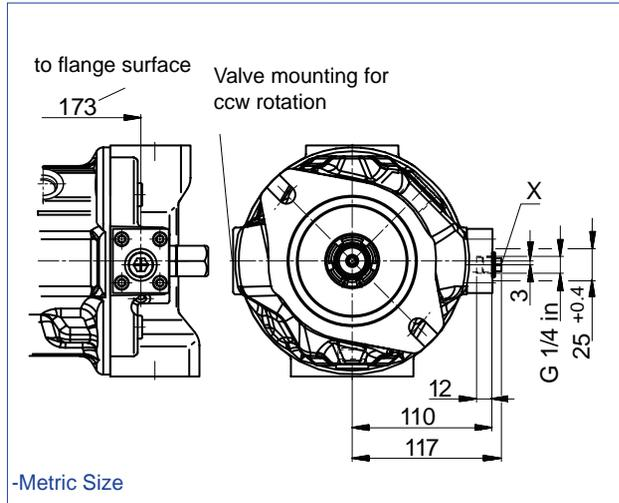

DFLR
Pressure, flow and power control

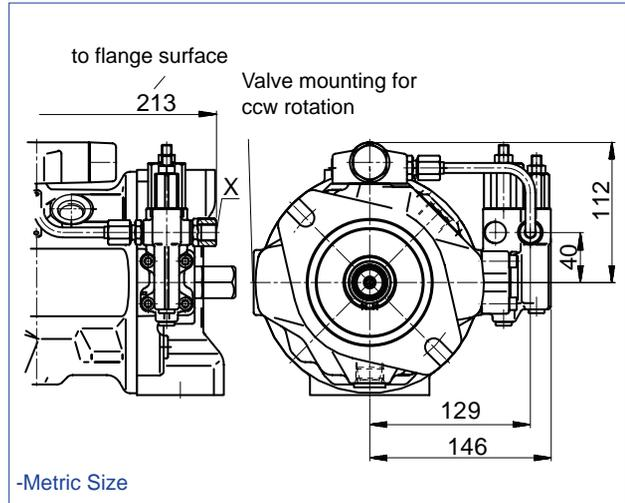

DR
Pressure control

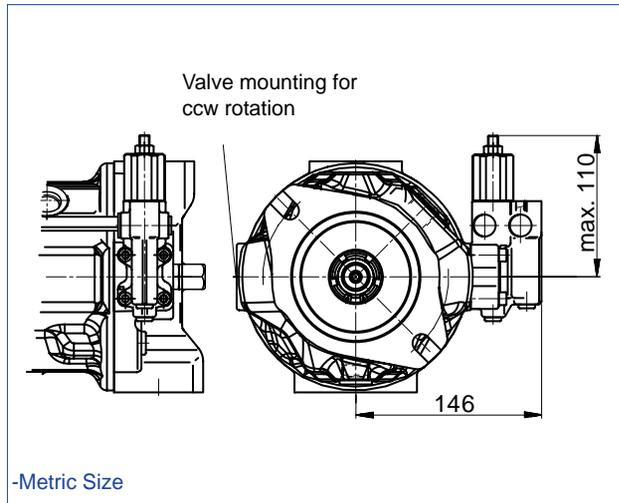

DRG
Pressure control, remotely operated

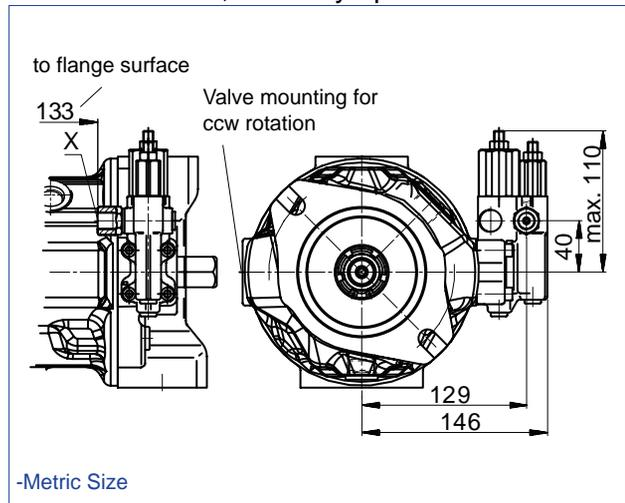

ED7. / ER7.
Electro-hydraulic pressure control

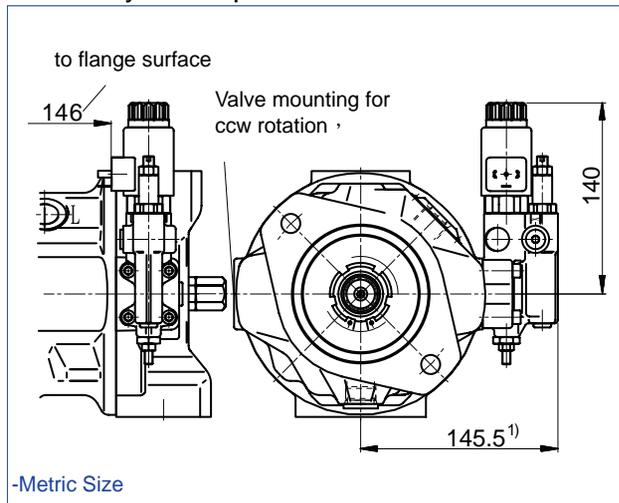

1) ER7.: 180.5 mm if using a sandwich plate pressure reducing valve.

Dimensions size 71

DFR/DFR1 – Pressure and flow control, hydraulic

Clockwise rotation

Before finalizing your design request a certified installation drawing. Dimensions in (mm).

A

25

PA10VSO - Metric Size

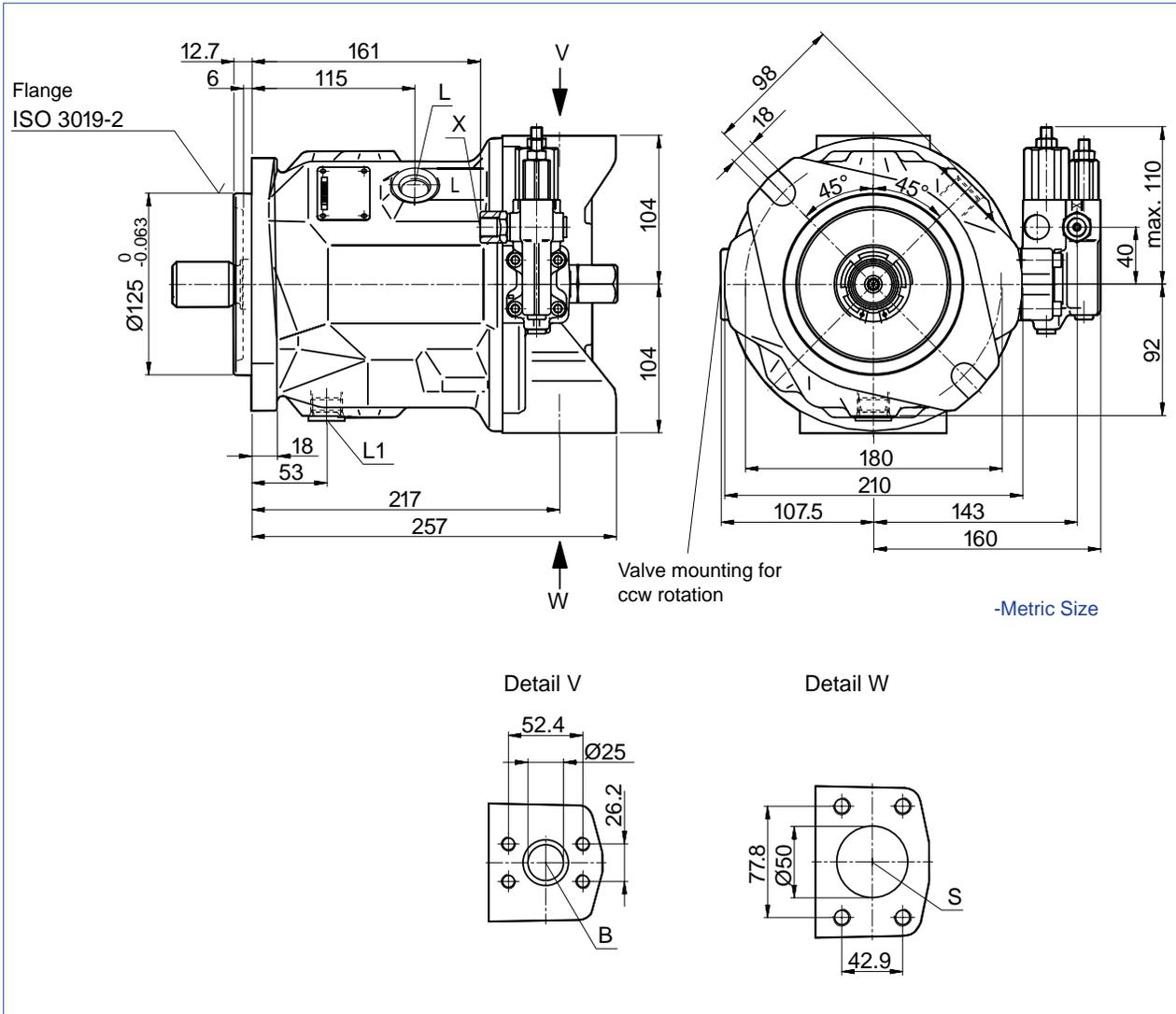

Ports

Designation	Port for	Standard	Size ¹⁾	Maximum pressure[psi(bar)] ²⁾	State
B	Service line, fastening thread	SAE J518 ³⁾ DIN 13	1 in M10 x 1.5 : 17 (deep)	500(350)	O
S	Suction line, fastening thread	SAE J518 ³⁾ DIN 13	2 in M12 x 1.75 : 20 (deep)	145(10)	O
L	Case drain fluid	DIN 3852 ⁴⁾	M22 x 1.5 : 14 (deep)	30(2)	O ⁵⁾
L ₁	Case drain fluid	DIN 3852 ⁴⁾	M22 x 1.5 : 14 (deep)	30(2)	X ⁵⁾
X	Pilot pressure	DIN 3852 ⁴⁾	M14 x 1.5 : 12 (deep)	5100(350)	O
X	Pilot press. with DG-control	DIN ISO 228 ⁴⁾	G 1/4 in	5100(350)	O

- 1) For the maximum tightening torques the general instructions on page A-64 must be observed.
- 2) Depending on the application, short-term pressure spikes can occur. Keep this in mind when selecting measuring equipment and fittings. Pressure values in bar absolute.
- 3) The dimension follow SAE J518, Metric fastening thread and standard thread are different.
- 4) The spot face can be deeper than as specified in the standard.
- 5) Depending on the installation position, L or L₁ must be connected (the following page A-62 \ A-63, please check assambling instruction.)
 O = Must be connected (plugged on delivery)
 X = Plugged (in normal operation)

Dimensions size 71

Before finalizing your design request a certified installation drawing. Dimensions in (mm).

Drive shaft

A

26

PA10VSO - Metric Size

S
Splined shaft 1 1/4 in
14T 12/24DP¹⁾ (SAE J744)

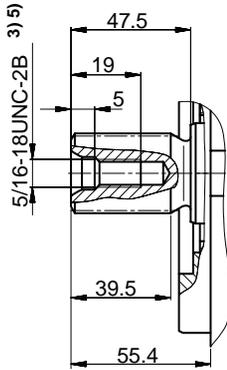

R
Splined shaft 1 1/4 in
14T 12/24DP¹⁾²⁾ (SAE J744)

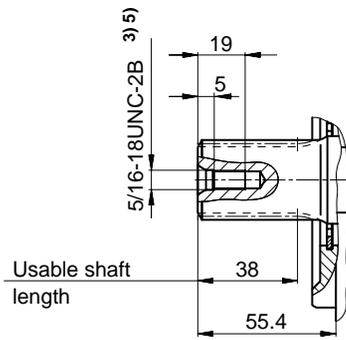

P
Parallel shaft key
DIN 6885 · A10x8x45

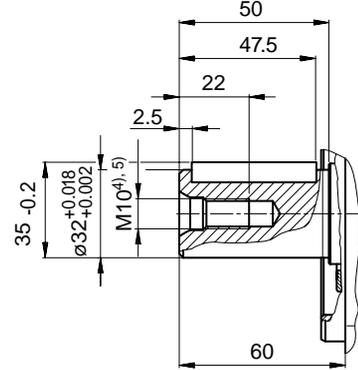

U
Splined shaft 1 in
15T 16/32DP¹⁾ (SAE J744)

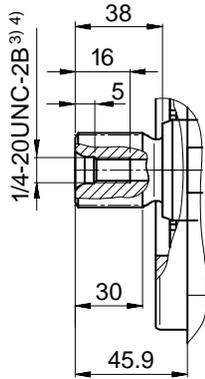

W
Splined shaft 1 in
15T 16/32DP¹⁾²⁾ (SAE J744)

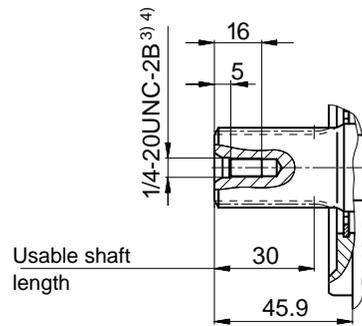

- 1) ANSI B92.1a, 30° pressure angle, flat root, side fit, tolerance class 5
- 2) Splines according to ANSI B92.1a, run out of spline is a deviation from standard
- 3) Thread according to ASME B1.1
- 4) Thread according to DIN 13
- 5) For the maximum tightening torques the general instructions on page A-64 must be observed.

Dimensions size 71

DG
Two-point control, directly operated

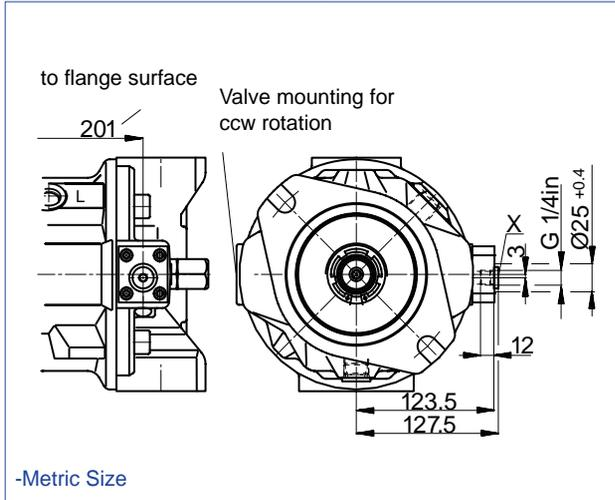

DFLR
Pressure, flow and power control

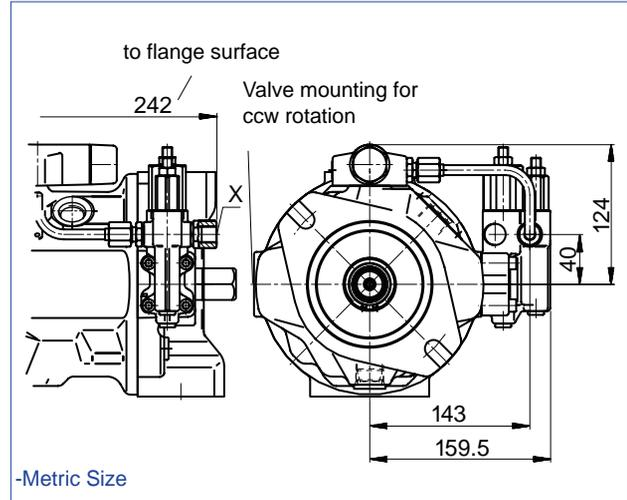

DR
Pressure control

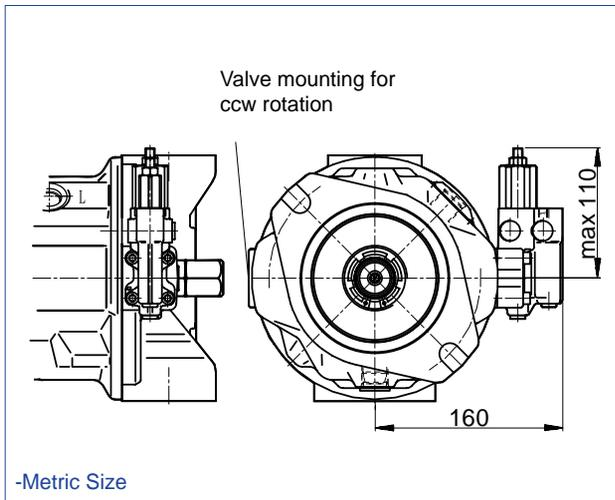

DRG
Pressure control, remotely operated

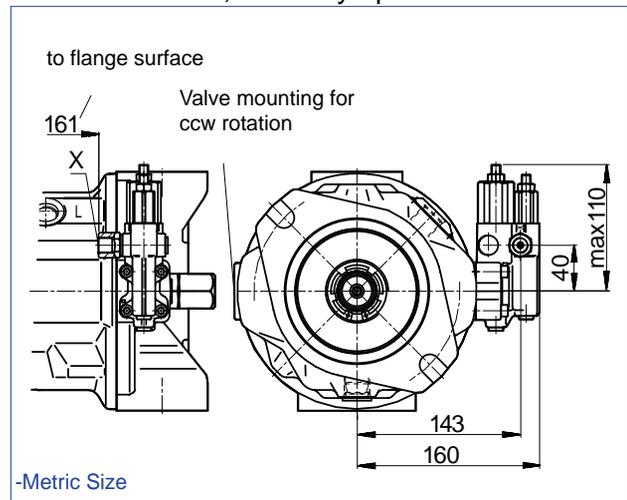

ED7. / ER7.
Electro-hydraulic pressure control

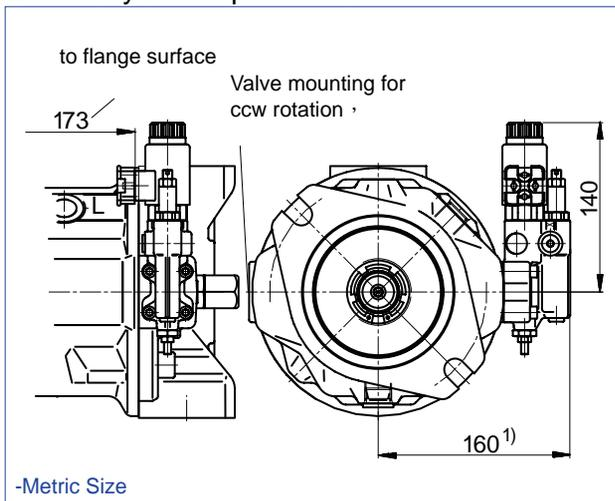

1) ER7.: 195 mm if using a sandwich plate pressure reducing valve.

Dimensions size 100

DFR/DFR1 – Pressure and flow control, hydraulic
Clockwise rotation

Before finalizing your design request a certified installation drawing.
Dimensions in (mm).

A

28

PA10VSO - Metric Size

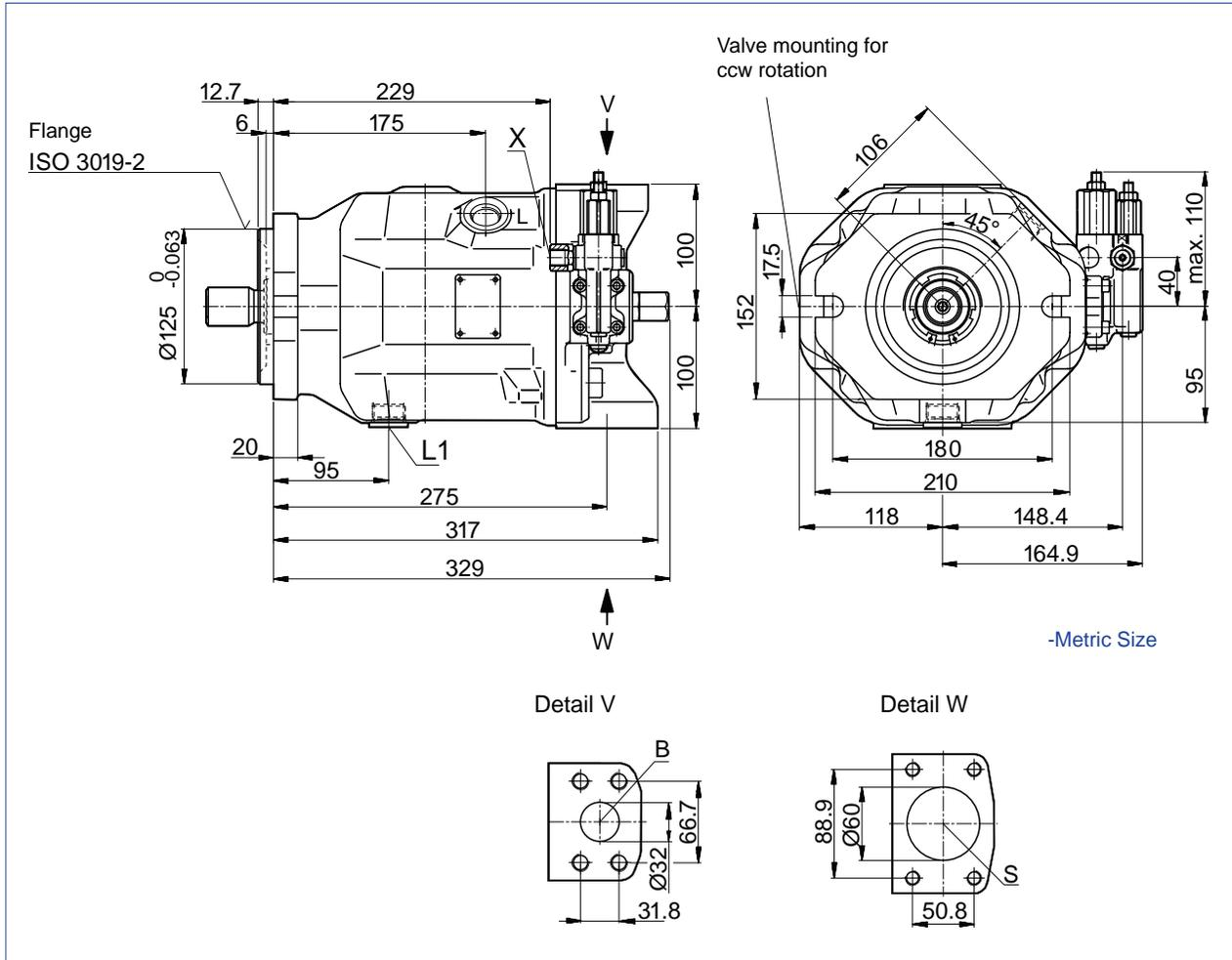

Ports

Designation	Port for	Standard	Size ¹⁾	Maximum pressure[psi(bar)] ²⁾	State
B	Service line, fastening thread	SAE J518 ³⁾ DIN 13	1 1/4 in M14 x 2 : 19 (deep)	5100(350)	O
S	Suction line, fastening thread	SAE J518 ³⁾ DIN 13	2 1/2in M12 x 1.75 : 17 (deep)	145(10)	O
L	Case drain fluid	DIN 3852 ⁴⁾	M27 x 2 : 16 (deep)	30(2)	O ⁵⁾
L1	Case drain fluid	DIN 3852 ⁴⁾	M27 x 2 : 16 (deep)	30(2)	X ⁵⁾
X	Pilot pressure	DIN 3852 ⁴⁾	M14 x 1.5 : 12 (deep)	5100(350)	O
X	Pilot press. with DG-control	DIN ISO 228 ⁴⁾	G 1/4 in	5100(350)	O

- For the maximum tightening torques the general instructions on page A-64 must be observed.
- Depending on the application, short-term pressure spikes can occur. Keep this in mind when selecting measuring equipment and fittings. Pressure values in bar absolute.
- The dimension follow SAE J518, Metric fastening thread and standard thread are different.
- The spot face can be deeper than as specified in the standard
- Depending on the installation position, L or L1 must be connected (the following page A-62 \ A-63, please check assembling instruction.)
O = Must be connected (plugged on delivery)
X = Plugged (in normal operation)

Dimensions size 100

Before finalizing your design request a certified installation drawing.
Dimensions in (mm).

Drive shaft

A

29

PA10VSO - Metric Size

S Splined shaft 1 1/2 in
17T 12/24DP¹⁾ (SAE J744)

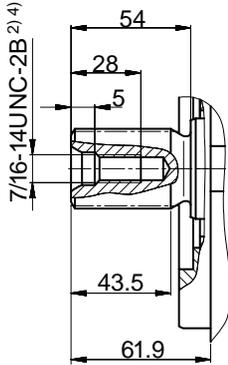

P Parallel shaft key
DIN 6885 · A12x8x68

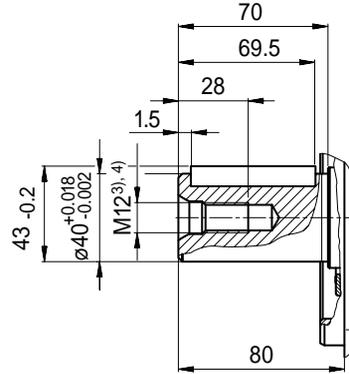

U Splined shaft 1 1/4 in
14T 12/24DP¹⁾ (SAE J744)

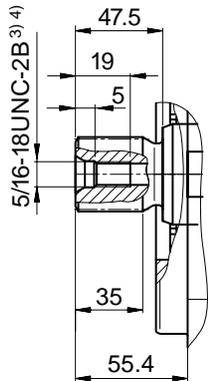

W Splined shaft 1 1/4 in
14T 12/24DP¹⁾⁽²⁾ (SAE J744)

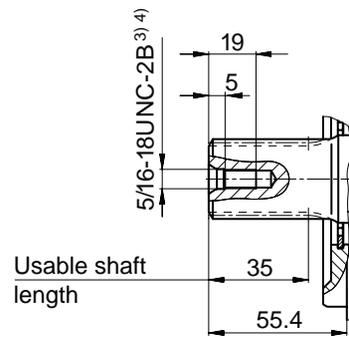

- 1) ANSI B92.1a, 30° pressure angle, flat root, side fit, tolerance class 5
- 2) Splines according to ANSI B92.1a, run out of spline is a deviation from standard
- 3) Thread according to ASME B1.1
- 4) Thread according to DIN 13
- 5) For the maximum tightening torques the general instructions on page A-64 must be observed.

Dimensions size 100

A

30

PA10VSO - Metric Size

Before finalizing your design request a certified installation drawing. Dimensions in (mm).

DG
Two-point control, directly operated

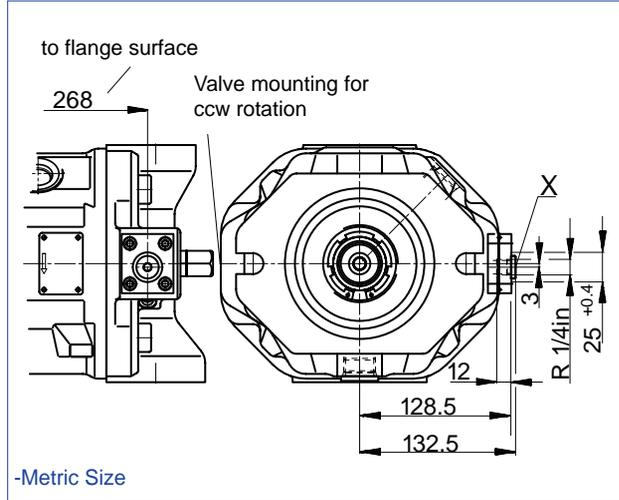

DFLR
Pressure, flow and power control

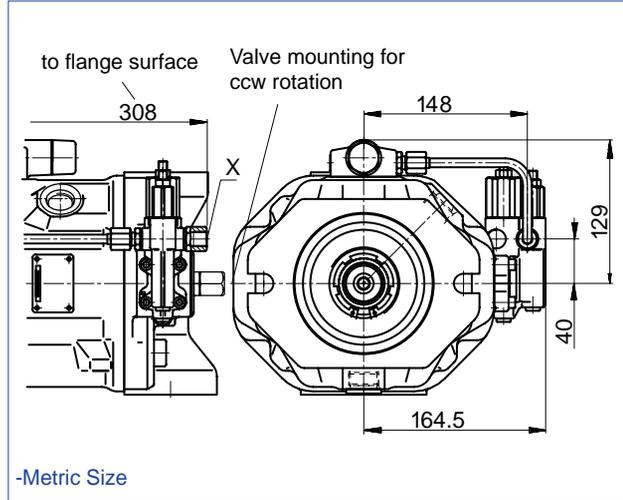

DR
Pressure control

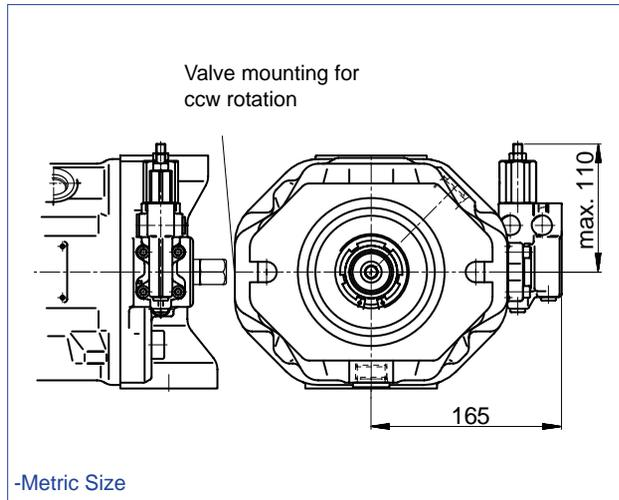

DRG
Pressure control, remotely operated

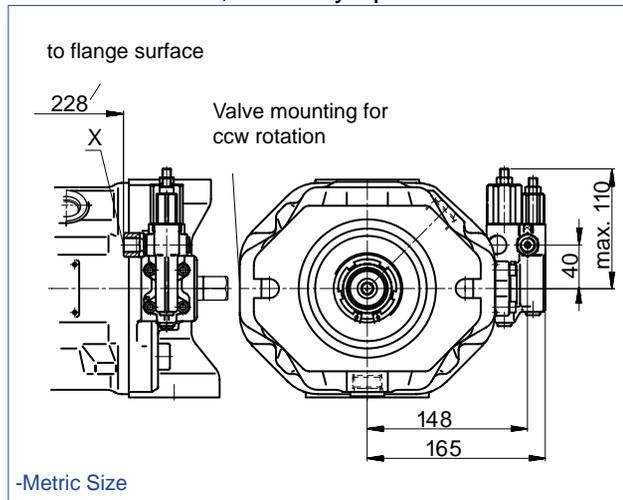

ED7. / ER7.
Electro-hydraulic pressure control

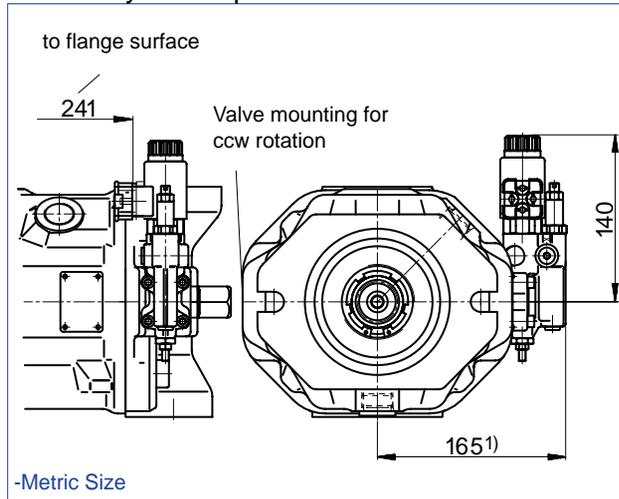

1) ER7.: 200 mm when using a sandwich plate pressure reducing valve.

Dimensions size 140

DFR/DFR1 — Pressure and flow control, hydraulic
 Clockwise rotation

Before finalizing your design request a certified installation drawing.
 Dimensions in (mm).

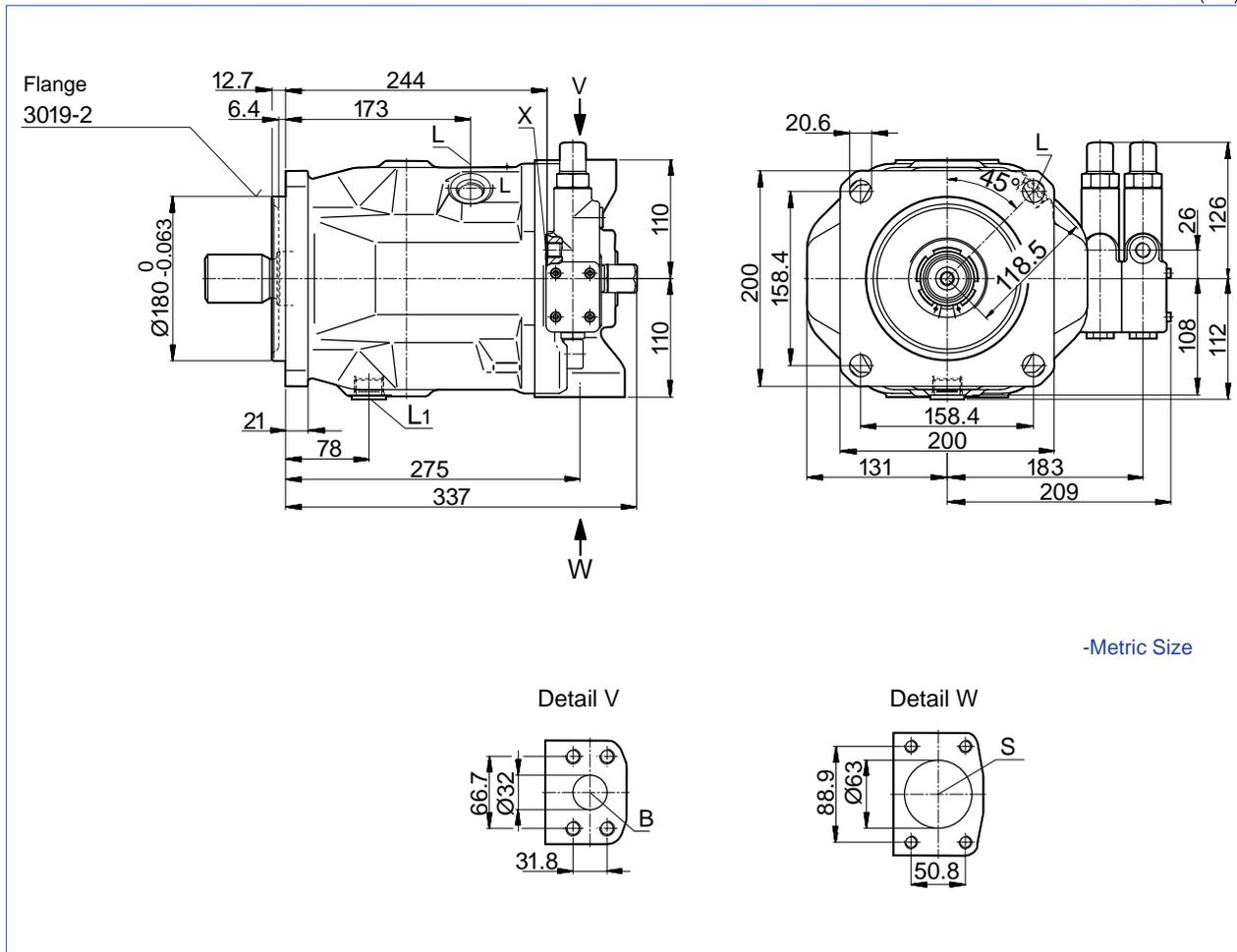

Ports

Designation	Port for	Standard	Size ¹⁾	Maximum pressure[psi(bar)] ²⁾	State
B	Service line, fastening thread	SAE J518 ³⁾ DIN 13	1 1/4 in M14 x 2 : 19 (deep)	5100(350)	O
S	Suction line, fastening thread	SAE J518 ³⁾ DIN 13	2 1/2 in M12 x 1.75 : 17 (deep)	145(10)	O
L	Case drain fluid	DIN 3852 ⁴⁾	M27 x 2 : 16 (deep)	30(2)	O ⁵⁾
L ₁	Case drain fluid	DIN 3852 ⁴⁾	M27 x 2 : 16 (deep)	30(2)	X ⁵⁾
X	Pilot pressure	DIN 3852 ⁴⁾	M14 x 1.5 : 12 (deep)	5100(350)	O
X	Pilot press. with DG-control	DIN 3852 ⁴⁾	M14 x 1.5 : 12 (deep)	5100(350)	O
M _H	Gauge port, high pressure	DIN 3852	M14 x 1.5 : 12 deep	5100(350)	X

- 1) For the maximum tightening torques the general instructions on page A-64 must be observed.
- 2) Depending on the application, short-term pressure spikes can occur. Keep this in mind when selecting measuring equipment and fittings. Pressure values in bar absolute.
- 3) The dimension follow SAE J518, Metric fastening thread and standard thread are different.
- 4) The spot face can be deeper than as specified in the standard
- 5) Depending on the installation position, L or L₁ must be connected (the following page A-62 \ A-63, please check assembling instruction.)
 O = Must be connected (plugged on delivery)
 X = Plugged (in normal operation)

Dimensions size 140

Before finalizing your design request a certified installation drawing.
Dimensions in (mm).

Drive

S Splined shaft 1 3/4 in
13T 8/16DP¹⁾ (SAE J744)

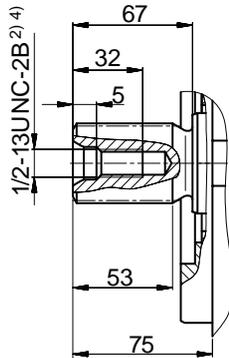

P Parallel shaft key
DIN 6885 · A14x9x80

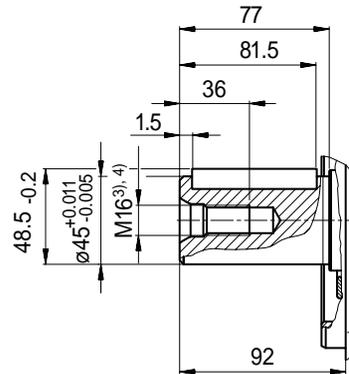

¹⁾ ANSI B92.1a, 30° pressure angle, flat root, side fit, tolerance class 5

²⁾ Thread according to ASME B1.1

³⁾ Thread according to DIN 13

⁴⁾ For the maximum tightening torques the general instructions on page A-64 must be observed.

Dimensions size 140

Before finalizing your design request a certified installation drawing. Dimensions in (mm).

DG
Two-point control, directly operated

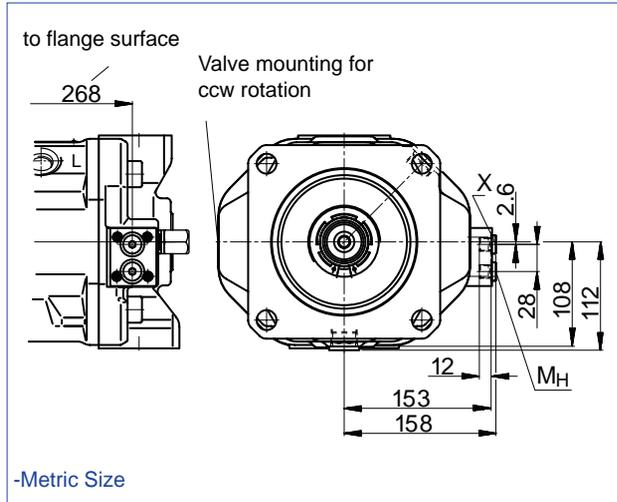

DFLR
Pressure, flow and power control

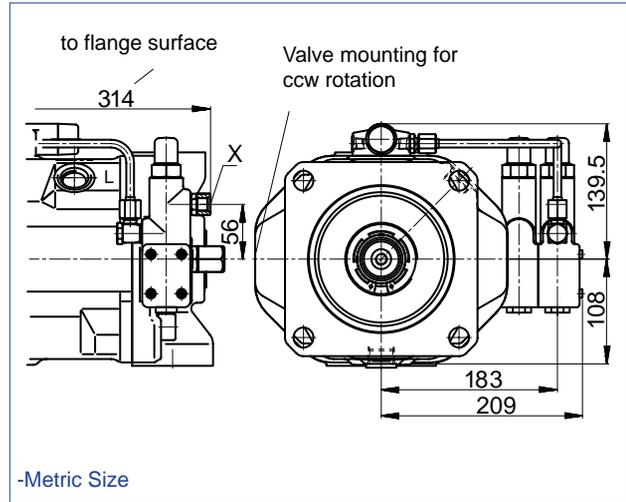

DR
Pressure control

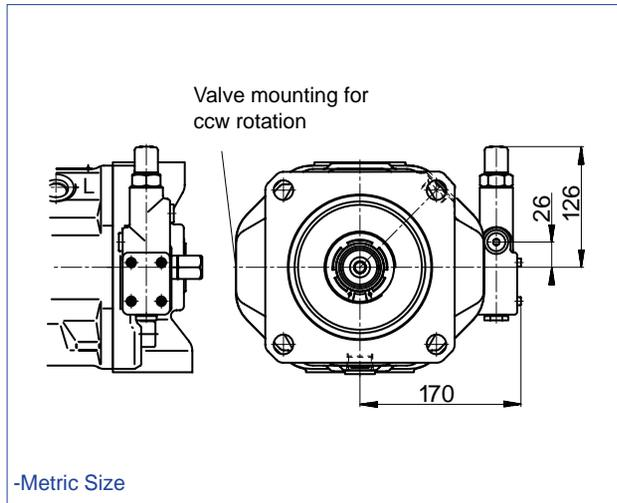

DRG
Pressure control, remotely operated

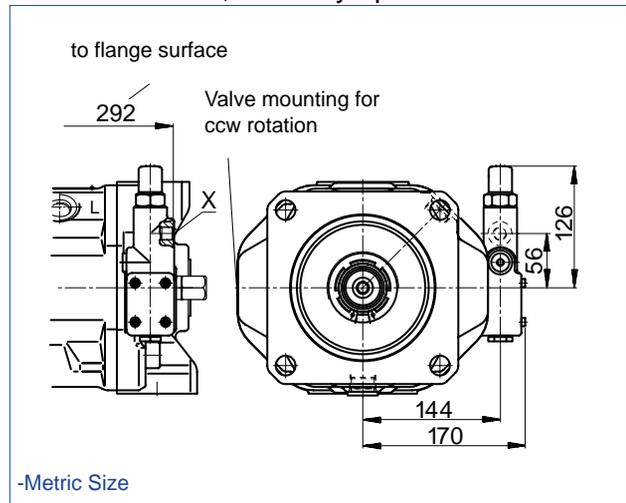

ED7. / ER7.
Electro-hydraulic pressure control

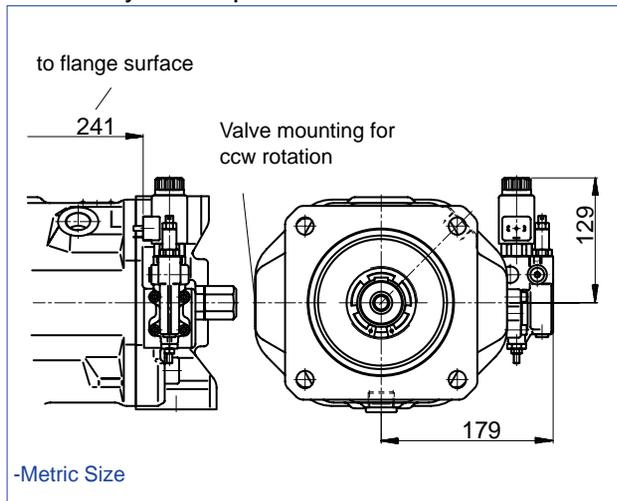

1) ER7.: 214 mm when using a sandwich plate pressure reducing valve.

Dimensions through drive

A

34

PA10VSO - Metric Size

K01 flange ISO 3019-1 (SAE J744 - 82-2 (A))
Coupling for splined shaft according to ANSI B92.1a-1996

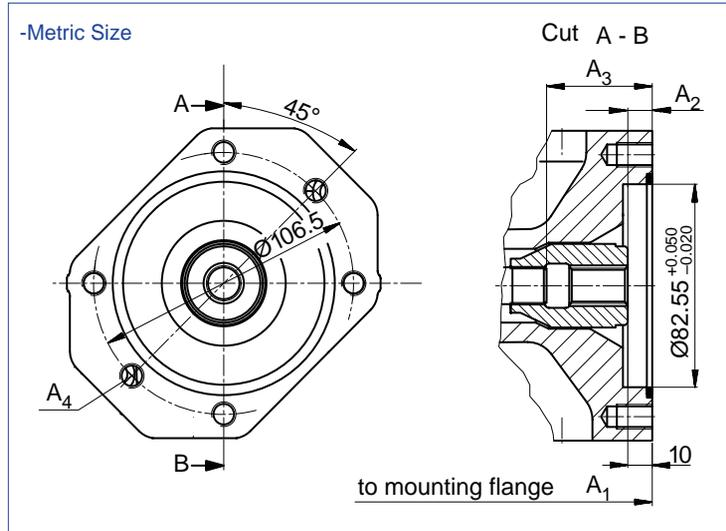

5/8 in 9T 16/32 DP¹⁾ (SAE J744 - 16-4 (A))

Inch (mm)		A ₁	A ₂	A ₃	A ₄ ²⁾
18	7.16 (182)	0.39 (10)	1.70 (43.3)	M10 x 1.5, 0.57(14.5) deep	
28	8.03 (204)	0.39 (10)	1.33 (33.7)	M10 x 1.5, 0.62(16) deep	
45	9.02 (229)	0.42 (10.7)	2.10 (53.4)	M10 x 1.5, 0.62(16) deep	
71	10.51 (267)	0.46 (11.8)	2.41 (61.3)	M10 x 1.5, 0.78(20) deep	
100	13.31 (338)	0.41 (10.5)	2.56 (65)	M10 x 1.5, 0.62(16) deep	
140	13.78 (350)	0.43 (10.8)	3.04 (77.3)	M10 x 1.5, 0.62(16) deep	

K52 flange ISO 3019-2 (SAE J744 - 82-2 (A))
Coupling for splined shaft according to ANSI B92.1a-1996

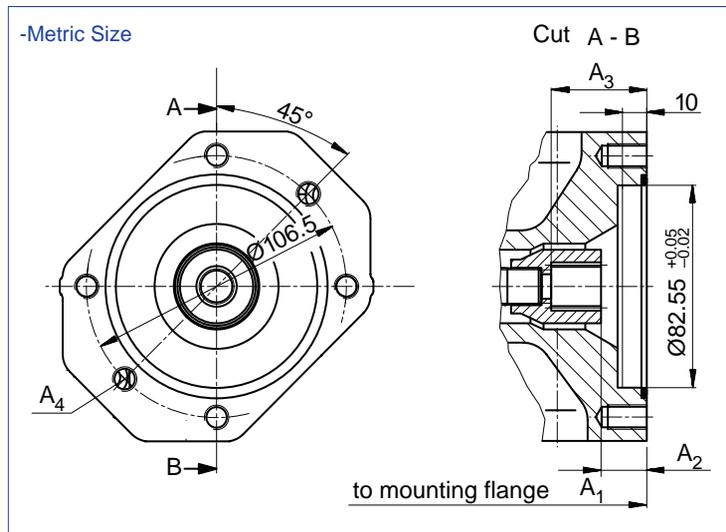

3/4 in 11T 16/32 DP¹⁾(SAE J744 - 19-4 (A-B))

Inch (mm)		A ₁	A ₂	A ₃	A ₄ ²⁾
18	7.16 (182)	0.74 (18.8)	1.52 (38.7)	M10 x 1.5, 0.57(14.5) deep	
28	8.03 (204)	0.74 (18.8)	1.52 (38.7)	M10 x 1.5, 0.62(16) deep	
45	9.02 (229)	0.744 (18.9)	1.52 (38.7)	M10 x 1.5, 0.62(16) deep	
71	10.51 (267)	0.84 (21.3)	1.63 (41.4)	M10 x 1.5, 0.78(20) deep	
100	13.31 (338)	0.75 (19)	1.53 (38.9)	M10 x 1.5, 0.62(16) deep	
140	13.78 (350)	0.744 (18.9)	1.52 (38.6)	M10 x 1.5, 0.62(16) deep	

K68 flange ISO 3019-2 (SAE J744 - 101-2 (B))
Coupling for splined shaft according to ANSI B92.1a-1996

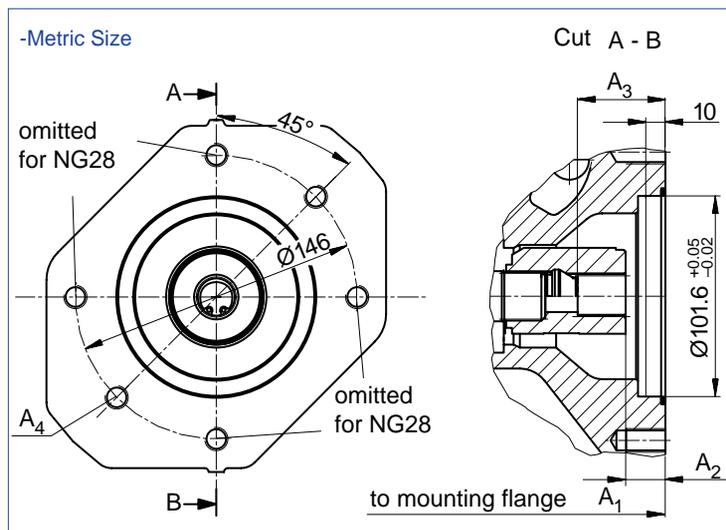

7/8 in 13T 16/32 DP¹⁾ (SAE J744 - 22-4 (B))

Inch (mm)		A ₁	A ₂	A ₃	A ₄ ²⁾
28	8.03 (204)	0.70 (17.8)	1.64 (41.7)	M12x 1.75, continuous	
45	9.02 (229)	0.704 (17.9)	1.64 (41.7)	M12 x 1.75, 0.71(18) deep	
71	10.51 (267)	0.80 (20.3)	1.74 (44.1)	M12 x 1.75, 0.78(20) deep	
100	13.31 (338)	0.71 (18)	1.65 (41.9)	M12 x 1.75, 0.78(20) deep	
140	13.78 (350)	0.70 (17.8)	1.64 (41.6)	M12 x 1.75, 0.78(20) deep	

1) 30° pressure angle, flat root, side fit, tolerance class 5

2) Thread according to DIN 13, observe the general instructions on page A-64 for the maximum tightening torques.

Dimensions through drive

K04 flange ISO 3019-2 (SAE J744 - 101-2 (B))
Coupling for splined shaft according to ANSI B92.1a-1996

Before finalizing your design request a certified installation drawing.
Dimensions in (mm).

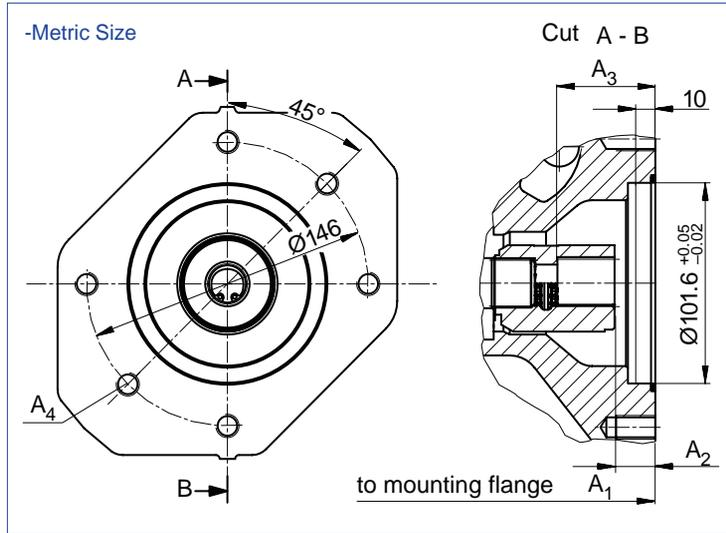

1 in 15T 16/32 DP¹⁾ (SAE J744 - 25-4 (B-B))
Inch (mm)

NG	A ₁	A ₂	A ₃	A ₄ ²⁾
45	9.02 (229)	0.724 (18.4)	1.84 (46.7)	M12 x 1.75, 0.71(18) deep
71	10.51 (267)	0.82 (20.8)	1.93 (49.1)	M12 x 1.75, 0.78(20) deep
100	13.31 (338)	0.716 (18.2)	1.83 (46.6)	M12 x 1.75, 0.78(20) deep
140	13.78 (350)	0.72 (18.3)	1.81 (45.9)	M12 x 1.75, 0.78(20) deep

K07 flange ISO 3019-2 (SAE J744 - 127-2 (C))
Coupling for splined shaft according to ANSI B92.1a-1996

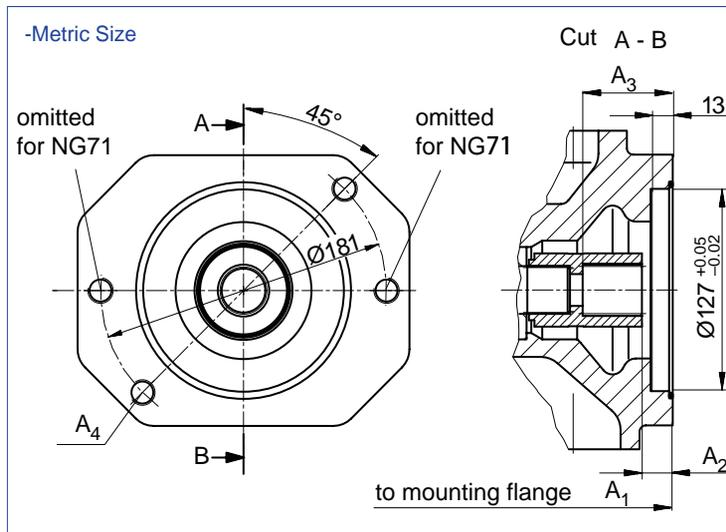

1 1/4 in 14T 12/24 DP¹⁾ (SAE J744 - 32-4 (C))
Inch (mm)

NG	A ₁	A ₂	A ₃	A ₄ ²⁾
71	10.51 (267)	0.86 (21.8)	2.31 (58.6)	M16 x 2, continuous
100	13.31 (338)	0.77 (19.5)	2.22 (56.4)	M6 x 2, continuous
140	13.78 (350)	0.76 (19.3)	2.21 (56.1)	M16 x 2, 0.94(24) deep

K24 flange ISO 3019-2 (SAE J744 - 127-2 (C))
Coupling for splined shaft according to ANSI B92.1a-1996

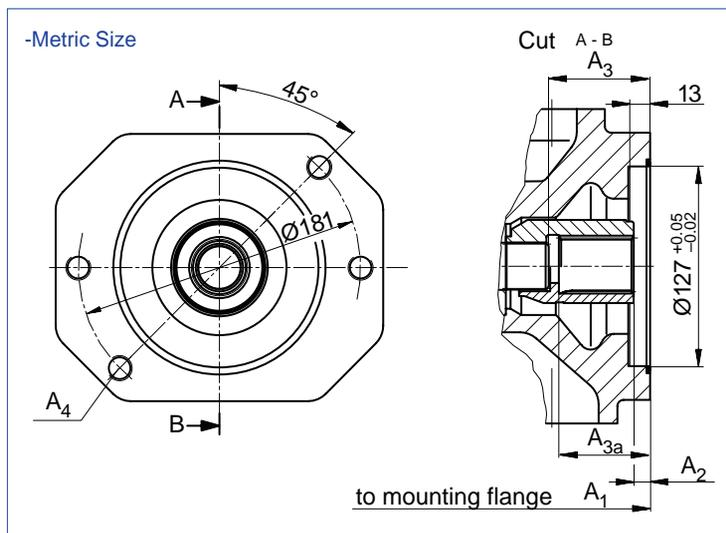

1 1/2 in 17T 12/24 DP¹⁾ (SAE J744 - 38-4 (C-C))
Inch (mm)

NG	A ₁	A ₂	A ₃ ³⁾	A _{3a} ⁴⁾	A ₄ ²⁾
100	13.31 (338)	0.41 (10.5)	2.56 (65)	-	M16 x 2, continuous
140	13.78 (350)	0.42 (10.8)	2.95 (75)	-	M16 x 2, 0.94 (24) deep
	13.78 (350)	0.40 (10.3)	-	2.72 (69.1)	M16 x 2, 0.94 (24) deep

- 3) Coupling without stop
- 4) Coupling with stop

1) 30° pressure angle, flat root, side fit, tolerance class 5
2) Thread according to DIN 13, observe the general instructions on page A-64 for the maximum tightening torques.

Dimensions through drive

A

36

PA10VSO - Metric Size

K17 flange ISO 3019-2 (SAE J744 - 152-4 (A))
Coupling for splined shaft according to ANSI B92.1a-1996

Before finalizing your design request a certified installation drawing. Dimensions in (mm).

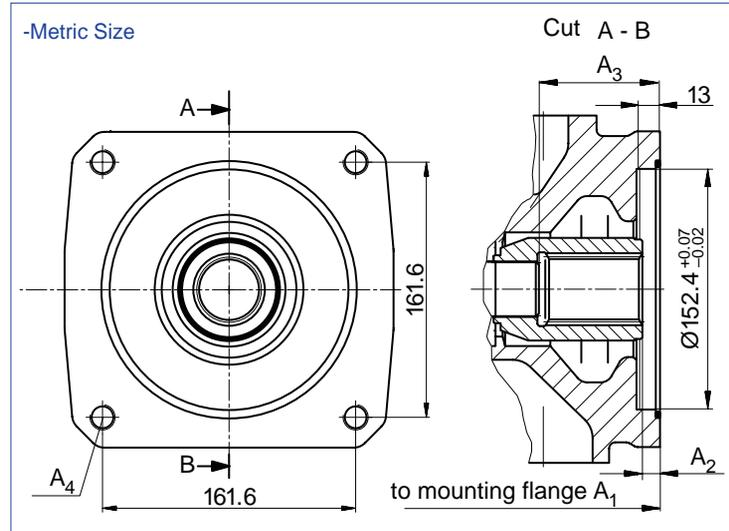

1 3/4 in 13T 8/16 DP ¹⁾(SAE J744 - 44-4 (D))

Inch (mm)

NG	A ₁	A ₂	A ₃	A ₄ ²⁾
140	13.78 (350)	0.43 (11)	3.04 (77.3)	M6 x 2, continuous

K57 flange for mounting R4 radial piston pump of metric 4 hole flange coupling for metric parallel shaft key.

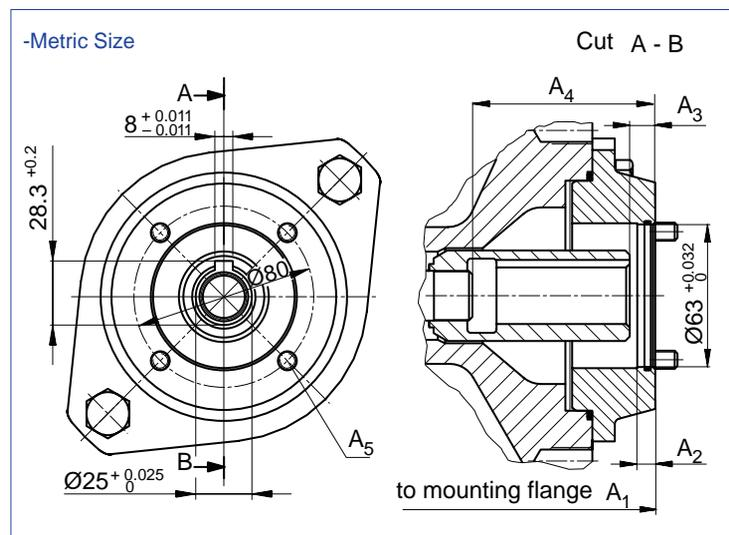

mm

NG	A ₁	A ₂	A ₃	A ₄	A ₅ ³⁾
28	232	8	10.6	58.4	M8
45	257	8	11	81	M8
71	283	8	12.5	77	M10
100	354	8	10.5	81	M10
140	366	8	11	93	M8

- 1) 30° pressure angle, flat root, side fit, tolerance class 5°
- 2) Thread according to DIN 13, observe the general instructions on page A-64 for the maximum tightening torques.
- 3) Screws for mounting the radial piston motor are included in the delivery contents.

Dimensions through drive

KB2 flange ISO 3019-2 - 80A2SW
Coupling for splined shaft according to ANSI B92.1a-1996

Before finalizing your design request a certified installation drawing. Dimensions in (mm).

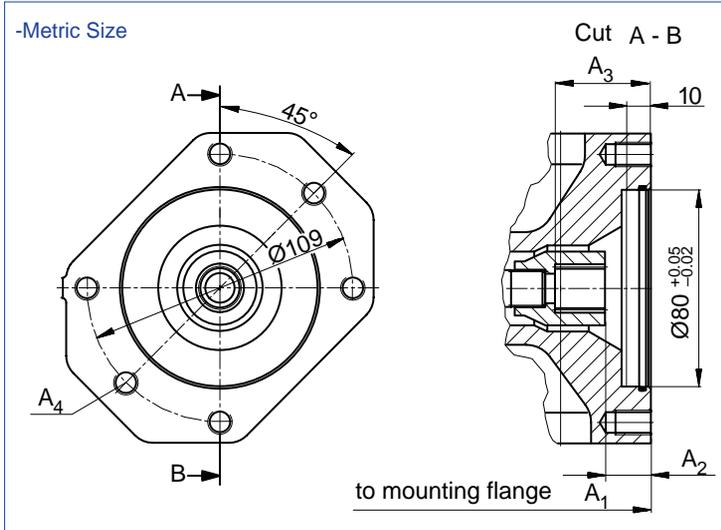

3/4 in 11T 16/32 DP ¹⁾ (SAE J744 - 19-4 (A-B))
mm

NG	A ₁	A ₂	A ₃	A ₄ ²⁾
18	182	18.8	38.7	M10 x 1.5 · 14.5 deep
28	204	18.8	38.7	M10 x 1.5 · 16 deep
45	229	18.9	38.7	M10 x 1.5 · 16 deep
71	267	21.3	41.4	M10 x 1.5 · 20 deep
100	338	19	38.9	M10 x 1.5 · 20 deep
140	350	18.9	38.6	M10 x 1.5 · 20 deep

KB3 flange ISO 3019-2 - 100A2SW
Coupling for splined shaft according to ANSI B92.1a-1996

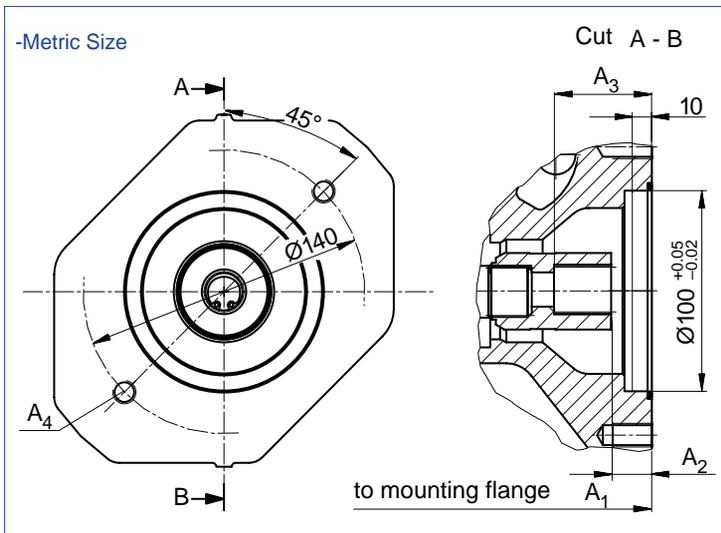

7/8 in 13T 16/32 DP ¹⁾ (SAE J744 - 22-4 (B))
mm

NG	A ₁	A ₂	A ₃	A ₄ ²⁾
28	204	17.8	41.7	M12 x 1.5 · continuous
45	229	17.9	41.7	M12 x 1.5 · continuous
71	267	20.3	44.1	M12 x 1.5 · 20 deep
100	338	18	41.9	M12 x 1.5 · 20 deep
140	350	17.8	41.6	M12 x 1.5 · 20 deep

KB4 flange ISO 3019-2 - 100A2SW
Coupling for splined shaft according to ANSI B92.1a-1996

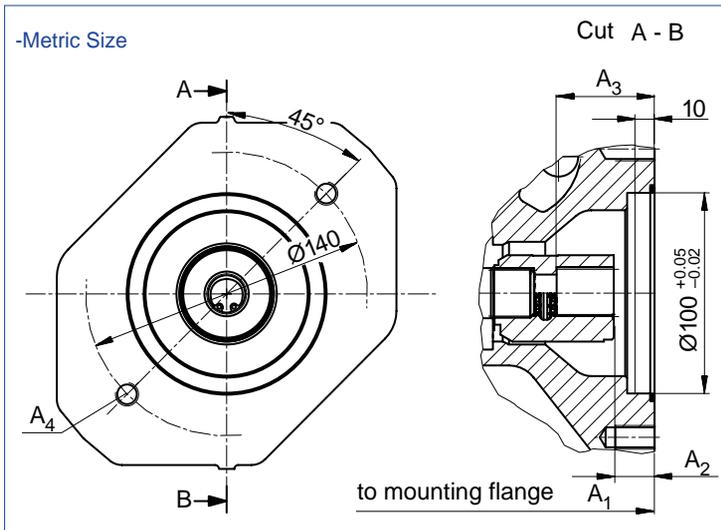

1 in 15T 16/32 DP ¹⁾ (SAE J744 - 25-4 (B-B))
mm

NG	A ₁	A ₂	A ₃	A ₄ ²⁾
45	229	18.4	46.7	M12 x 1.75 · continuous
71	267	20.8	49.1	M12 x 1.75 · 20 deep
100	338	18.2	46.6	M12 x 1.75 · 20 deep
140	350	18.3	45.9	M12 x 1.75 · 20 deep

- 30° pressure angle, flat root, side fit, tolerance class 5
- Thread according to DIN 13, observe the general instructions on page A-64 for the maximum tightening torques.

Dimensions through drive

A

38

PA10VSO - Metric Size

KB5 flange ISO 3019-2 - 125A2SW
Coupling for splined shaft according to ANSI B92.1a-1996

Before finalizing your design request a certified installation drawing. Dimensions in (mm).

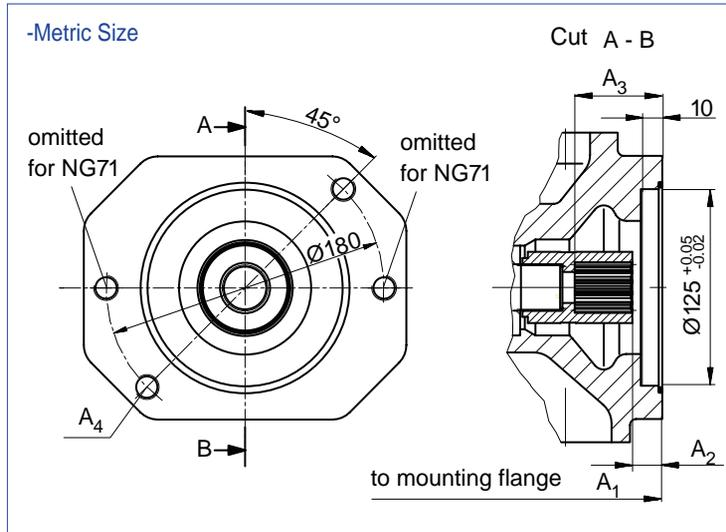

1 1/4 in 14T 12/24 DP ¹⁾ (SAE J744 - 32-4 (C))

mm

NG	A ₁	A ₂	A ₃	A ₄ ²⁾
71	267	21.8	58.6	M16 x 2 , continuous
100	338	19.5	56.4	M16 x 2 , continuous
140	350	19.3	56.1	M16 x 2 , 24 deep

KB6 flange ISO 3019-2 - 125A2SW
Coupling for splined shaft according to ANSI B92.1a-1996

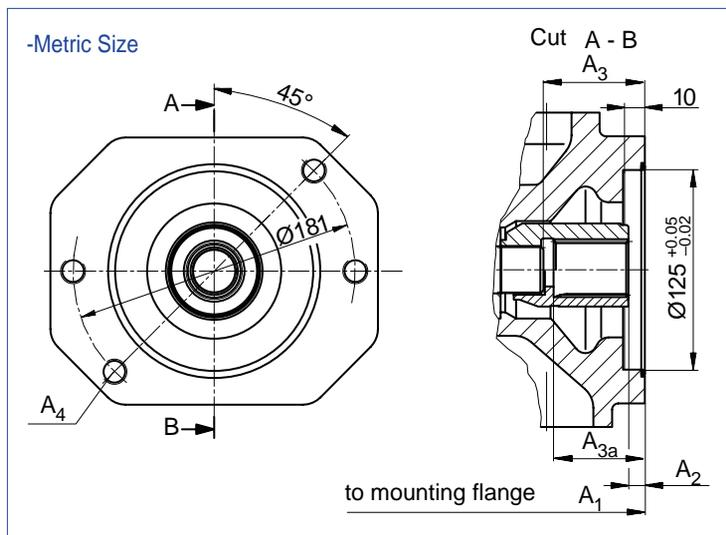

1 1/2 in 17T 12/24 DP ¹⁾ (SAE J744 - 38-4 (C-C))

mm

NG	A ₁	A ₂	A ₃ ³⁾	A _{3a} ⁴⁾	A ₄ ²⁾
100	338	10.5	65	-	M16 x 2 , continuous
140	350	10.8	75	-	M16 x 2 , 24 deep
	350	10.3	-	69.1	M16 x 2 , 24 deep

KB7 flange ISO 3019-2 - 180B4HW
Coupling for splined shaft according to ANSI B92.1a-1996

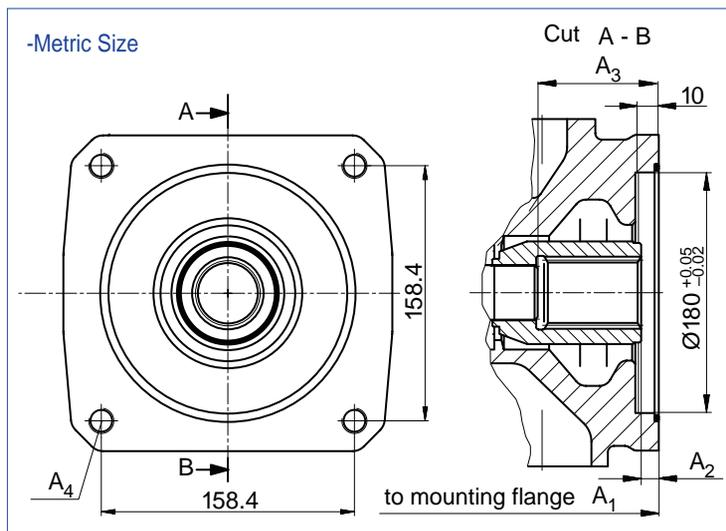

1 3/4 in 13T 8/16 DP ¹⁾ (SAE J744 - 44-4 (D))

mm

NG	A ₁	A ₂	A ₃	A ₄ ²⁾
140	350	11.3	77.3	M16 x 2 , continuous

3) Coupling without stop

4) Coupling with stop

1) 30° pressure angle, flat root, side fit, tolerance class 5

2) Thread according to DIN 13, observe the general instructions on page A-64 for the maximum tightening torques.

Dimensions size 18

DFR, DFR1 – Pressure and flow control, hydraulic
Clockwise rotation

Before finalizing your design request a certified installation drawing.
Dimensions in inches and (mm).

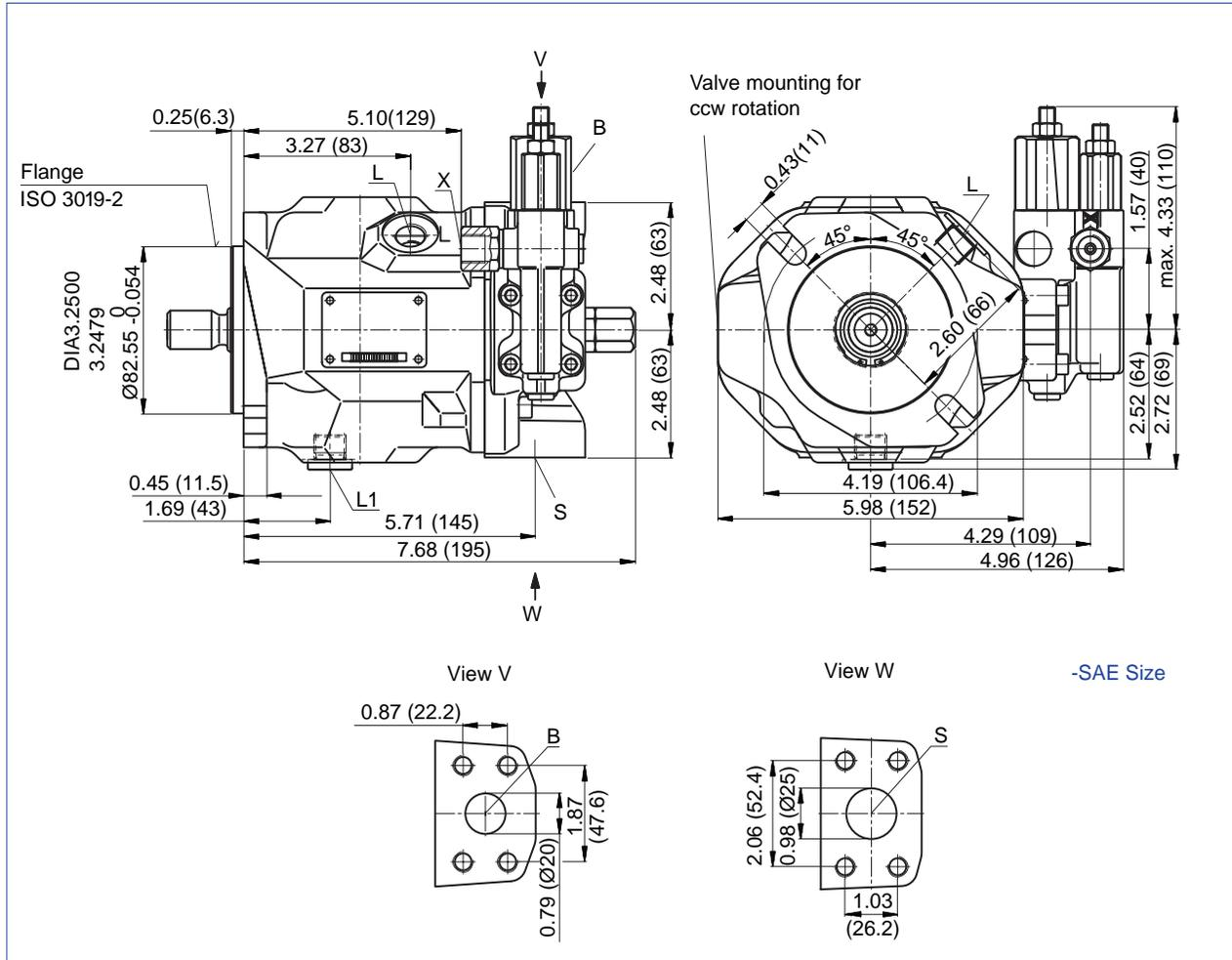

Ports

Designation	Port for	Standard	Size ¹⁾	Maximum pressure [psi(bar)] ²⁾	State
B	Service line, fastening thread	SAE J518 ASME B1.1	3/4 in 3/8-16 UNC-2B; 0.79 (20) deep	5100(350)	O
S	Suction line, fastening thread	SAE J518 ASME B1.1	1 in 3/8-16 UNC-2B; 0.79 (20) deep	145(10)	O
L	Case drain fluid	ISO 11926 ³⁾	9/16-18 UNF-2B; 0.47 (12) deep	30(2)	O ⁴⁾
L1	Case drain fluid	ISO 11926 ³⁾	9/16-18 UNF-2B; 0.47 (12) deep	30(2)	X ⁴⁾
X	Pilot pressure	ISO 11926 ³⁾	7/16-20 UNF-2B; 0.45 (12) deep	5100(350)	O
X	Pilot press. with DG-control	DIN ISO 228 ³⁾	G 1/4 in; 0.47 (12) deep	5100(350)	O

- For the maximum tightening torques the general instructions on page A-64 must be observed.
- Depending on the application, short-term pressure spikes can occur. Keep this in mind when selecting measuring equipment and fittings. Pressure values in bar absolute.
- The spot face can be deeper than as specified in the standard.
- Depending on the installation position, L or L1 must be connected (the following page A-62 \ A-63, please check assembling instruction.)
O = Must be connected (plugged on delivery)
X = Plugged (in normal operation)

Dimensions size 18

Before finalizing your design request a certified installation drawing.
Dimensions in inches and (mm).

Drive shaft

S Splined shaft 3/4 in
11T 16/32DP¹⁾ (SAE J744)

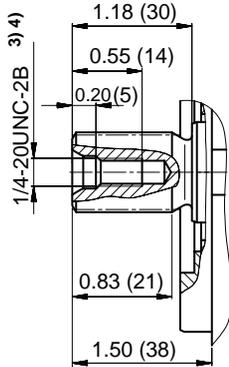

R Splined shaft 3/4 in
11T 16/32DP¹⁾²⁾ (SAE J744)

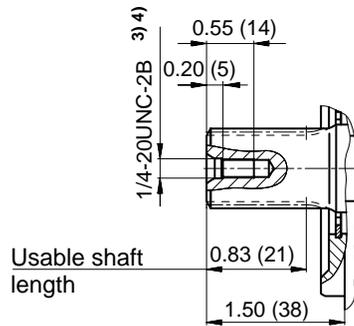

U Splined shaft 5/8 in
9T 16/32DP¹⁾ (SAE J744)

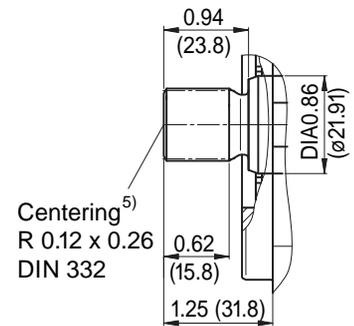

K Parallel shaft key
ISO 3019-1,19-1

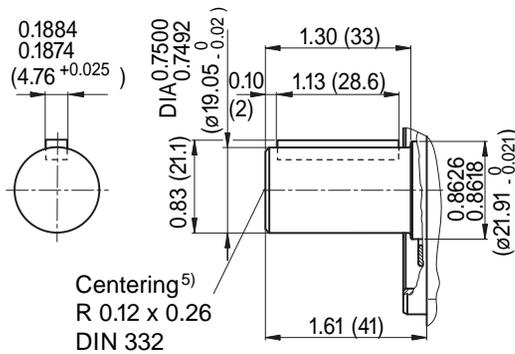

- 1) ANSI B92.1a, 30° pressure angle, flat root, side fit, tolerance class 5
- 2) Splines according to ANSI B92.1a, run out of spline is a deviation from standard
- 3) Thread according to ASME B1.1
- 4) For the maximum tightening torques the general instructions on page A-64 must be observed
- 5) Coupling axially secured, e.g. with a clamp coupling or radially mounted clamping screw

Dimensions size 18

A

41

PA10VSO - SAE Size

Before finalizing your design request a certified installation drawing.
Dimensions in inches and (mm).

DG
Two-point control, directly operated

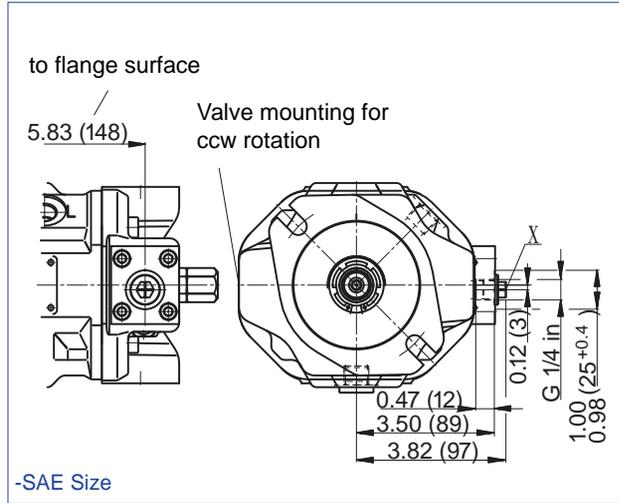

DR
Pressure control

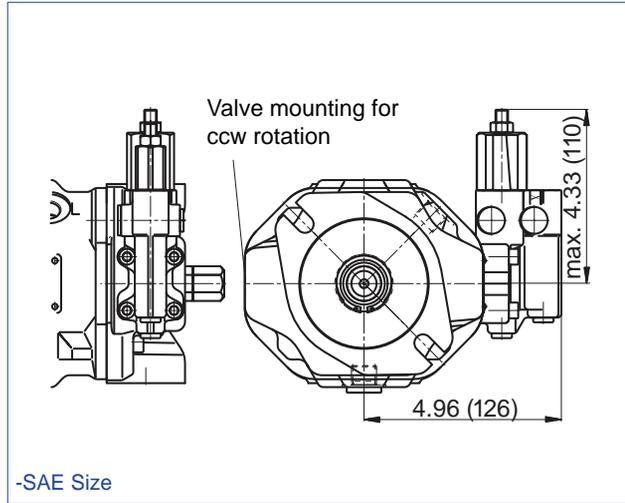

DRG
Pressure control, remotely operated

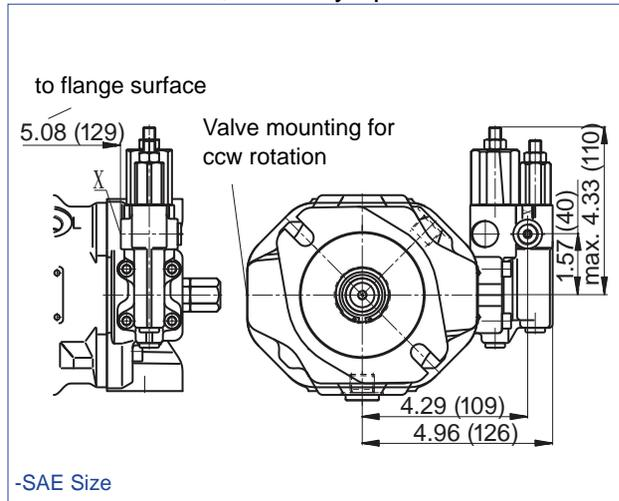

ED7., ER7.
Electro-hydraulic pressure control

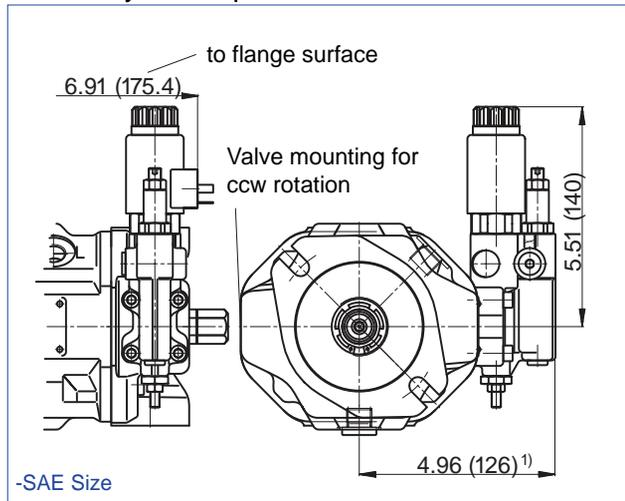

Dimensions size 28

DFR/DFR1 – Pressure and flow control, hydraulic
 Clockwise rotation

Before finalizing your design request a certified installation drawing.
 Dimensions in inches and (mm).

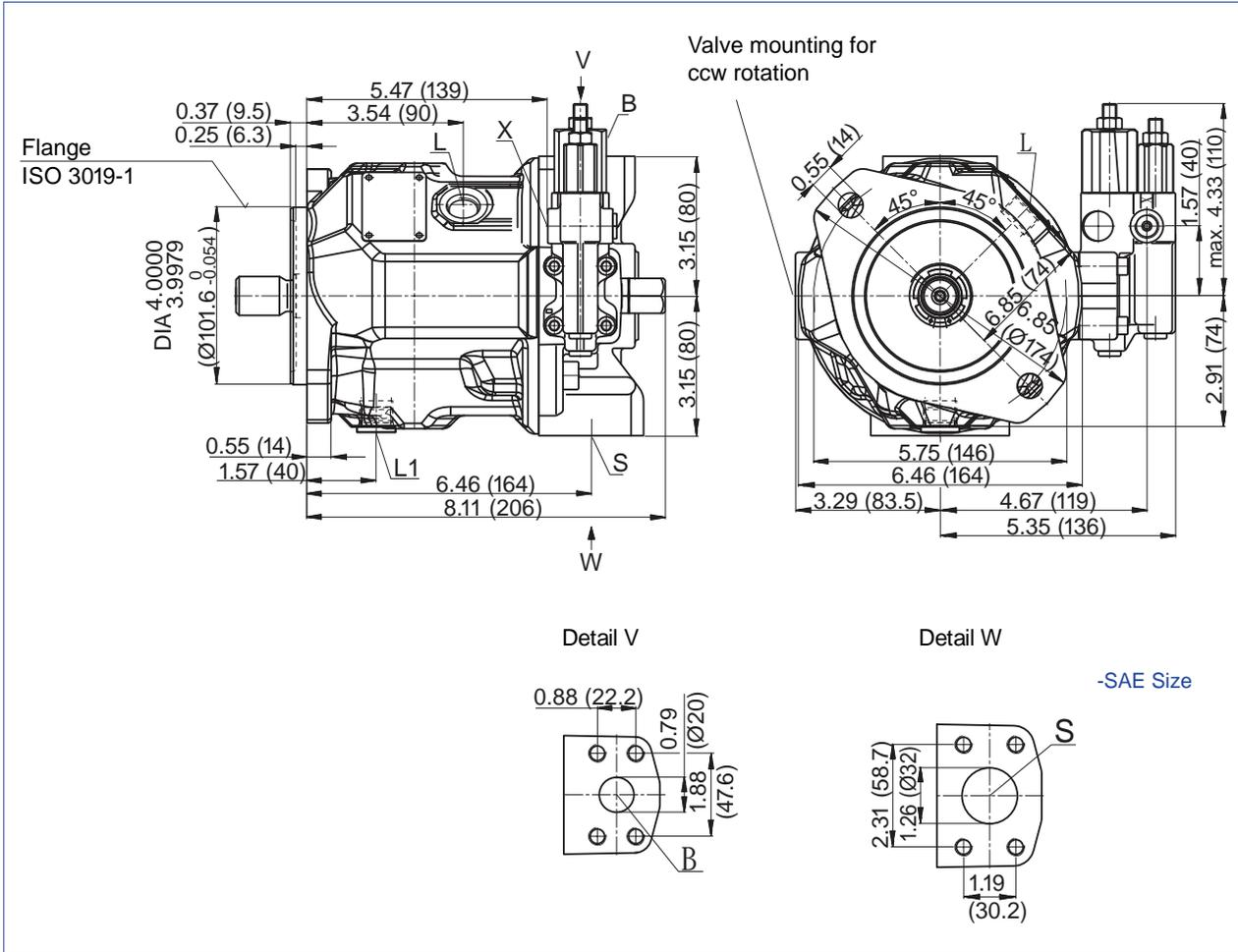

Ports

Designation	Port for	Standard	Size ¹⁾	Maximum pressure[psi(bar)] ²⁾	State
B	Service line, fastening thread	SAE J518 ASME B1.1	3/4 in 3/8-16 UNC-2B; 0.79 (20) deep	5100(350)	O
S	Suction line, fastening thread	SAE J518 ASME B1.1	1 1/4 in 7/16-14 UNC-2B; 0.94 (24) deep	145(10)	O
L	Case drain fluid	ISO 11926 ³⁾	3/4-16 UNF-2B; 0.47 (12) deep	30(2)	O ⁴⁾
L1	Case drain fluid	ISO 11926 ³⁾	3/4-16 UNF-2B; 0.47 (12) deep	30(2)	X ⁴⁾
X	Pilot pressure	ISO 11926 ³⁾	7/16-14 UNC-12B; 0.47 (12) deep	5100(350)	O
X	Pilot press. with DG-control	DIN ISO 228 ³⁾	G 1/4in; 0.47 (12) deep	5100(350)	O

- 1) For the maximum tightening torques the general instructions on page A-64 must be observed.
- 2) Depending on the application, short-term pressure spikes can occur. Keep this in mind when selecting measuring equipment and fittings. Pressure values in bar absolute.
- 3) The spot face can be deeper than as specified in the standard.
- 4) Depending on the installation position, L or L1 must be connected (the following page A-62 \ A-63, please check assambling instruction.)
 O = Must be connected (plugged on delivery)
 X = Plugged (in normal operation)

Dimensions size 28

Before finalizing your design request a certified installation drawing. Dimensions in inches and (mm).

Drive shaft

S
Splined shaft 7/8 in
13T 16/32DP¹⁾ (SAE J744)

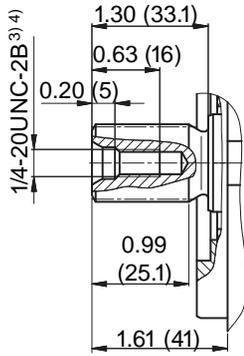

R
Splined shaft 7/8 in
13T 16/32DP¹⁾²⁾ (SAE J744)

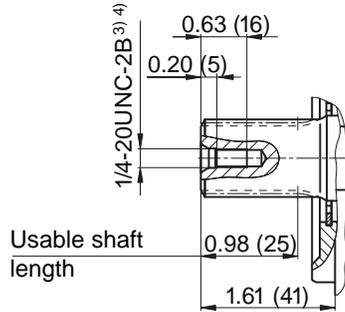

U
Splined shaft 3/4 in
11T 16/32DP¹⁾ (SAE J744)

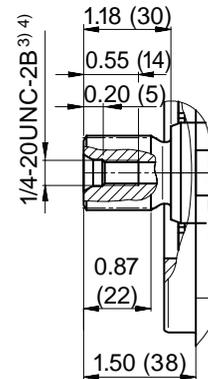

W
Splined shaft 3/4 in
11T 16/32DP¹⁾²⁾ (SAE J744)

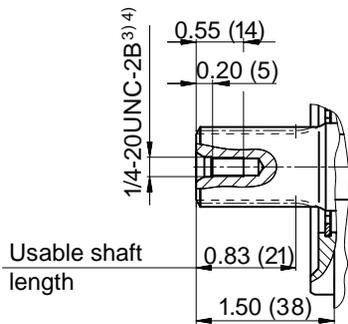

K
Parallel shaft key
ISO 3019-1, 22-1

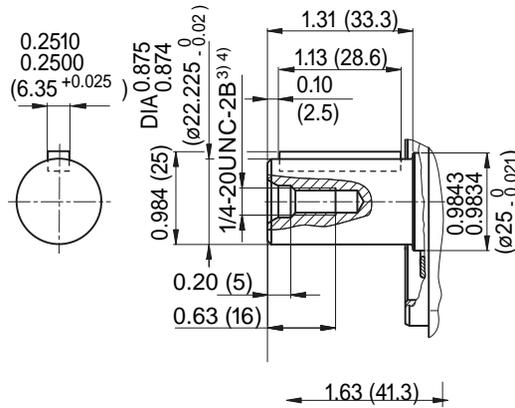

- 1) ANSI B92.1a, 30° pressure angle, flat root, side fit, tolerance class 5
- 2) Splines according to ANSI B92.1a, run out of spline is a deviation from standard
- 3) Thread according to ASME B1.1
- 4) For the maximum tightening torques the general instructions on page A-64 must be observed.

Dimensions size 28

Before finalizing your design request a certified installation drawing.
Dimensions in inches and (mm).

DG
Two-point control, directly operated

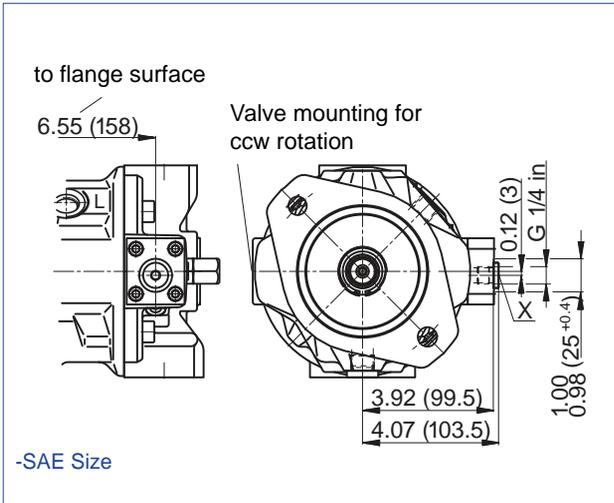

DFLR
Pressure, flow and power control

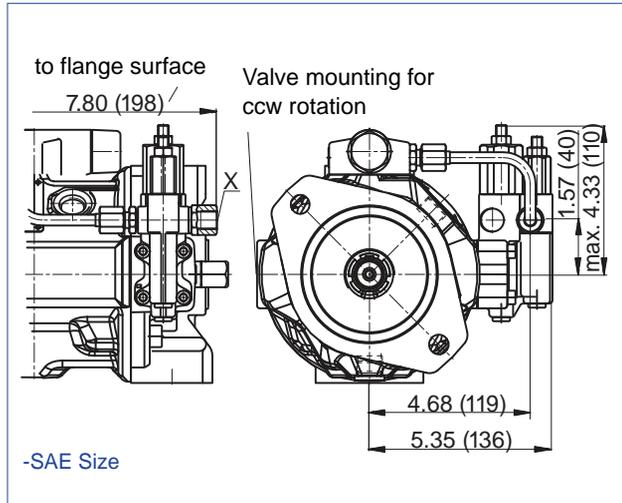

DR
Pressure control

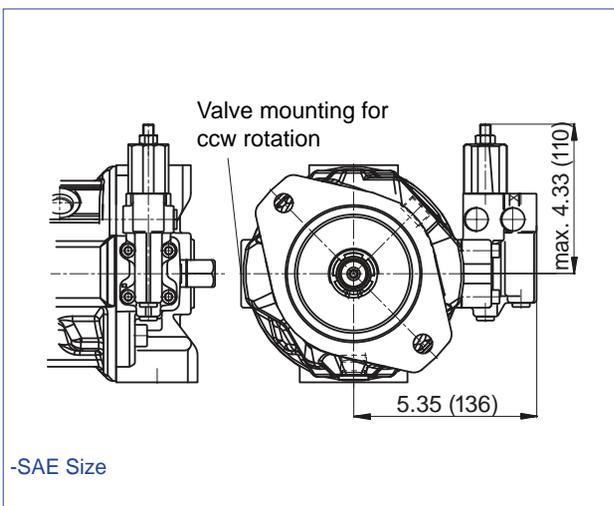

DRG
Pressure control, remotely operated

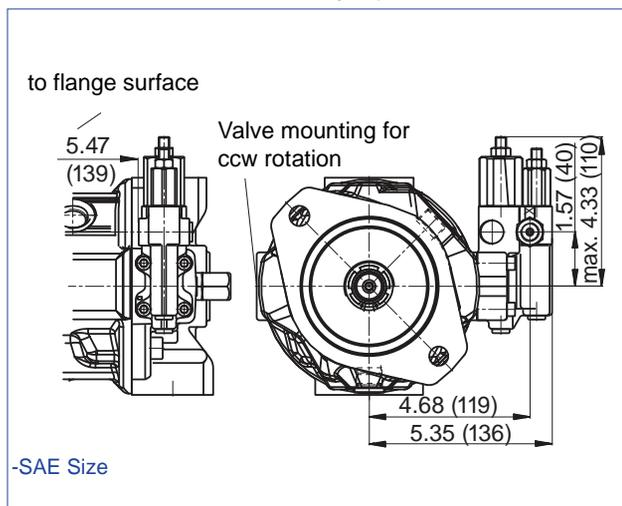

ED7. / ER7.
Electro-hydraulic pressure control

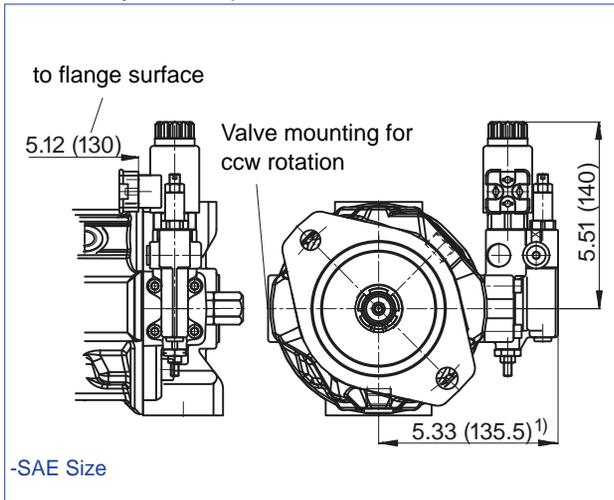

¹⁾ ER7.: 170.5 mm when using a sandwich plate pressure reducing valve.
For details of connection options and drive shafts, see also page A-42 and A-43.

Dimensions size 45

DFR/DFR1 – Pressure and flow control, hydraulic
Clockwise rotation

Before finalizing your design request a certified installation drawing.
Dimensions in inches and (mm).

A

45

PA10VSO - SAE Size

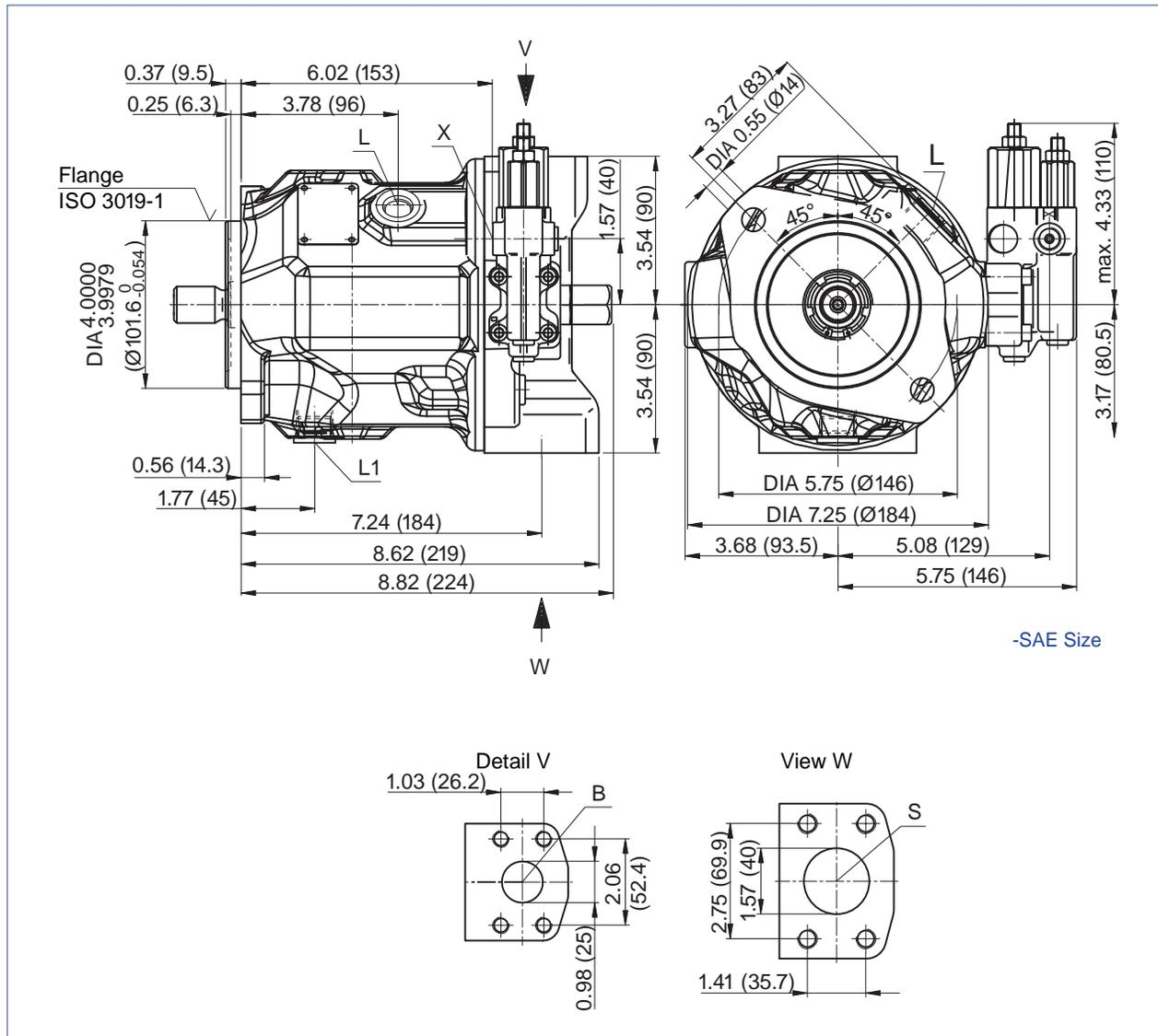

Ports

Designation	Port for	Standard	Size ¹⁾	Maximum pressure[psi(bar)] ²⁾	State
B	Service line, fastening thread	SAE J518 ASME B1.1	1 in 3/8-16 UNC-2B; 0.71 (18) deep	5100(350)	O
S	Suction line, fastening thread	SAE J518 ASME B1.1	1 1/2 in 1/2-13 UNC-2B; 0.87 (22) deep	145(10)	O
L	Case drain fluid	ISO 11926 ³⁾	7/8-14 UNF-2B; 0.55 (14) deep	30(2)	O ⁴⁾
L1	Case drain fluid	ISO 11926 ³⁾	7/8-14 UNF-2B; 0.55 (14) deep	30(2)	X ⁴⁾
X	Pilot pressure	ISO 11926 ³⁾	7/16-20 UNF-2B; 0.45 (12) deep	5100(350)	O
X	Pilot press. with DG-control	DIN ISO 228 ³⁾	G 1/4 in	5100(350)	O

- For the maximum tightening torques the general instructions on page A-64 must be observed.
- Depending on the application, short-term pressure spikes can occur. Keep this in mind when selecting measuring equipment and fittings. Pressure values in bar absolute.
- The spot face can be deeper than as specified in the standard.
- Depending on the installation position, L or L1 must be connected (the following page A-62 \ A-63, please check assembling instruction.)
O = Must be connected (plugged on delivery)
X = Plugged (in normal operation)

Dimensions size 45

Before finalizing your design request a certified installation drawing.
Dimensions in inches and (mm).

Drive shaft

S

Splined shaft 1 in
15T 16/32DP¹⁾ (SAE J744)

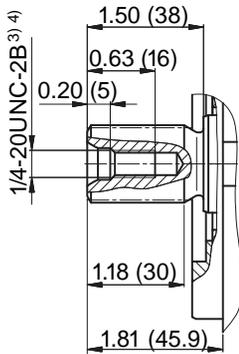

R

Splined shaft 1 in
15T 16/32DP¹⁾²⁾ (SAE J744)

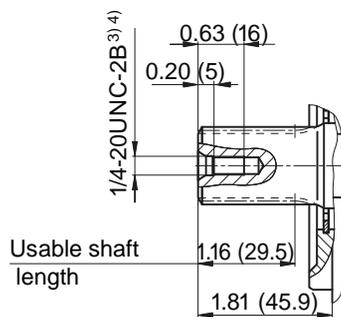

U

Splined shaft 7/8 in
13T 16/32DP¹⁾ (SAE J744)

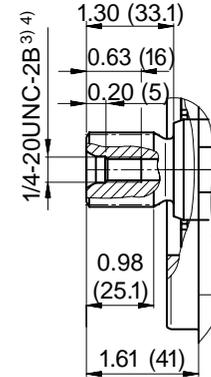

W

Splined shaft 7/8 in
13T 16/32DP¹⁾²⁾ (SAE J744)

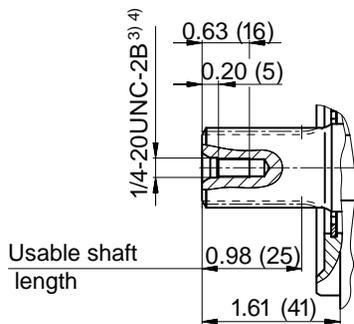

K

Parallel shaft key
ISO 3019-1, 25-1

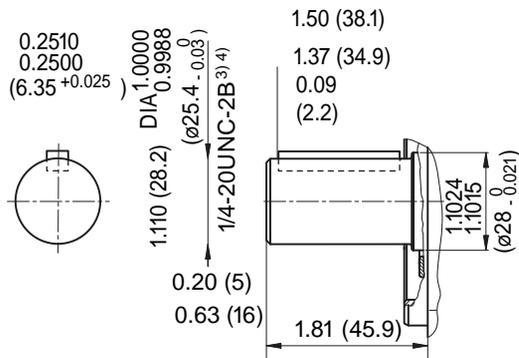

- 1) ANSI B92.1a, 30° pressure angle, flat root, side fit, tolerance class 5
- 2) Splines according to ANSI B92.1a, run out of spline is a deviation from standard
- 3) Thread according to ASME B1.1
- 4) For the maximum tightening torques the general instructions on page A-64 must be observed.

Dimensions size 45

A

47

PA10VSO - SAE Size

Before finalizing your design request a certified installation drawing.
Dimensions in inches and (mm).

DG
Two-point control, directly operated

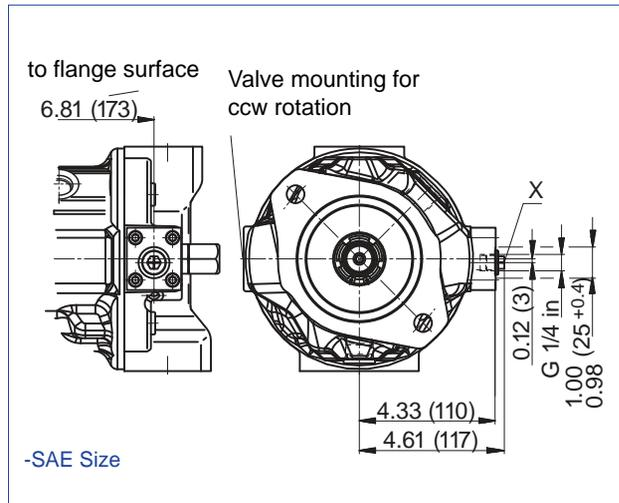

DFLR
Pressure, flow and power control

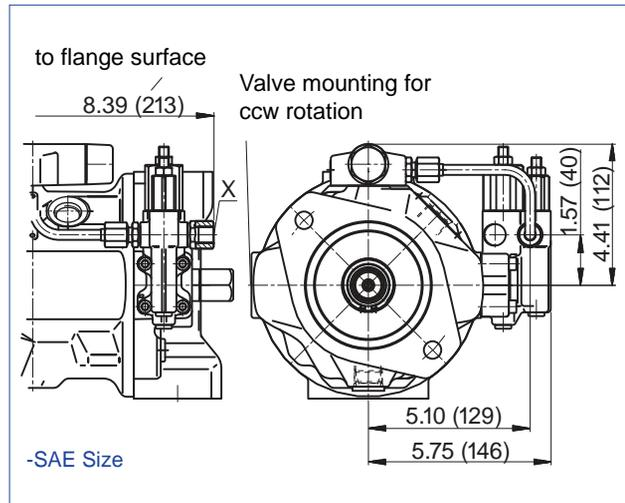

DR
Pressure control

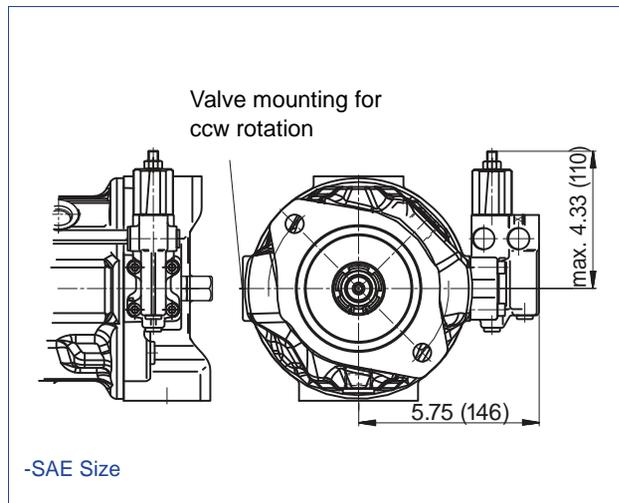

DRG
Pressure control, remotely operated

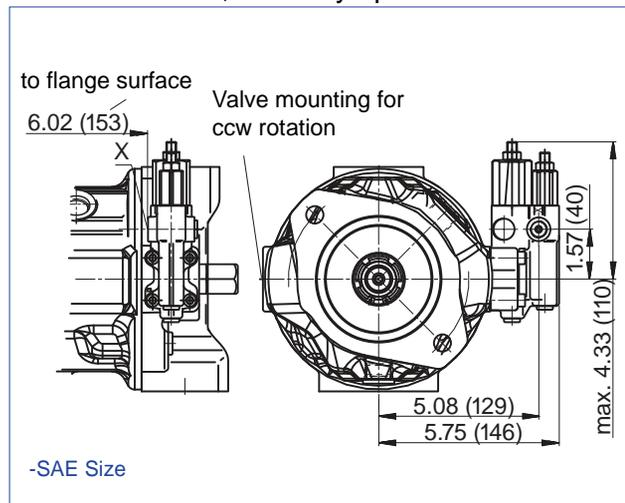

ED7. / ER7.
Electro-hydraulic pressure control

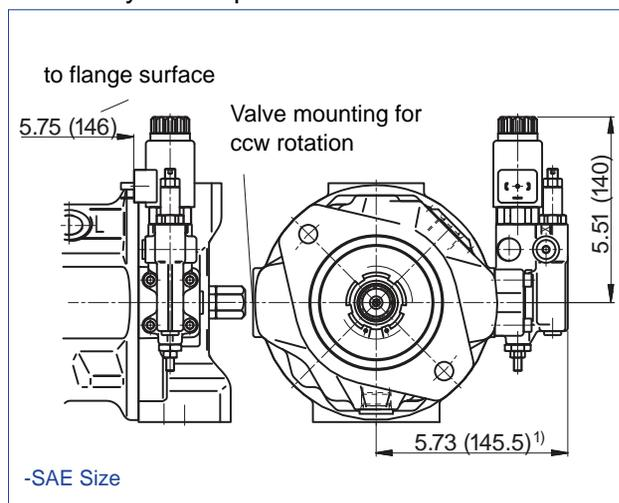

¹⁾ ER7.: 180.5 mm if using a sandwich plate pressure reducing valve.

Dimensions size 71

DFR/DFR1 – Pressure and flow control, hydraulic
Clockwise rotation

Before finalizing your design request a certified installation drawing.
Dimensions in inches and (mm).

A

48

PA10VSO - SAE Size

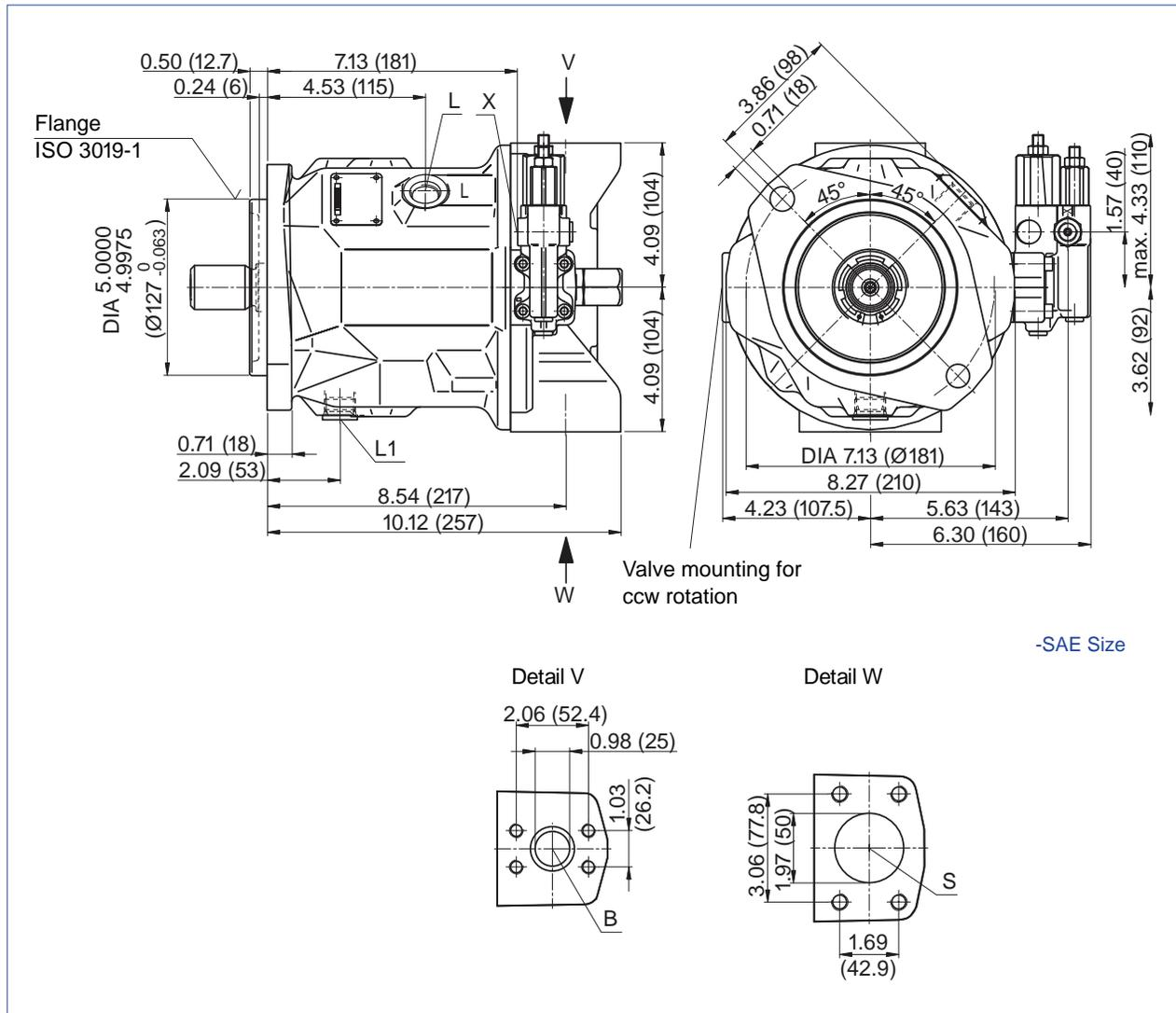

Ports

Designation	Port for	Standard	Size ¹⁾	Maximum pressure[psi(bar)] ²⁾	State
B	Service line, fastening thread	SAE J518 ASME B1.1	1 in 3/8-16 UNC-2B; 0.71 (18) deep	5100(350)	O
S	Suction line, fastening thread	SAE J518 ASME B1.1	2 in 1/2-13 UNC-2B; 0.87 (22) deep	145(10)	O
L	Case drain fluid	ISO 11926 ³⁾	7/8-14 UNF-2B; 0.55 (14) deep	30(2)	O ⁴⁾
L1	Case drain fluid	ISO 11926 ³⁾	7/8-14 UNF-2B; 0.55 (14) deep	30(2)	X ⁴⁾
X	Pilot pressure	ISO 11926 ³⁾	7/16-20 UNF-2B; 0.45 (12) deep	5100(350)	O
X	Pilot press. with DG-control	DIN ISO 228 ³⁾	G 1/4 in	5100(350)	O

- For the maximum tightening torques the general instructions on page A-64 must be observed.
- Depending on the application, short-term pressure spikes can occur. Keep this in mind when selecting measuring equipment and fittings. Pressure values in bar absolute.
- The spot face can be deeper than as specified in the standard.
- Depending on the installation position, L or L1 must be connected (the following page A-62 \ A-63, please check assembling instruction.)
O = Must be connected (plugged on delivery)
X = Plugged (in normal operation)

Dimensions size 71

Before finalizing your design request a certified installation drawing. Dimensions in inches and (mm).

Drive shaft

A

49

PA10VSO - SAE Size

S Splined shaft 1 1/4 in
14T 12/24DP¹⁾ (SAE J744)

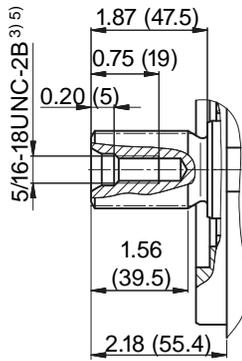

R Splined shaft 1 1/4 in
14T 12/24DP¹⁾²⁾ (SAE J744)

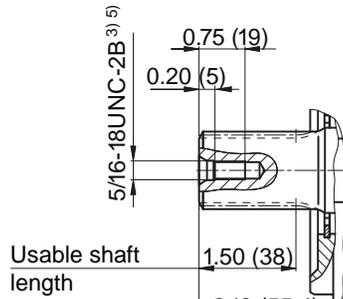

U Splined shaft 1 in
15T 16/32DP¹⁾ (SAE J744)

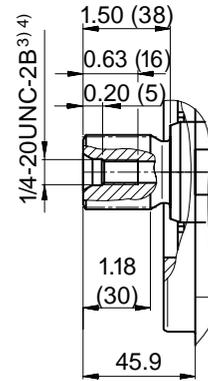

W Splined shaft 1 in
15T 16/32DP¹⁾²⁾ (SAE J744)

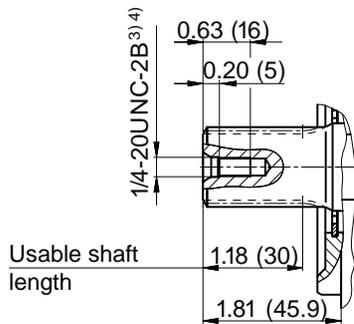

K Parallel shaft key
ISO 3019-1, 32-1

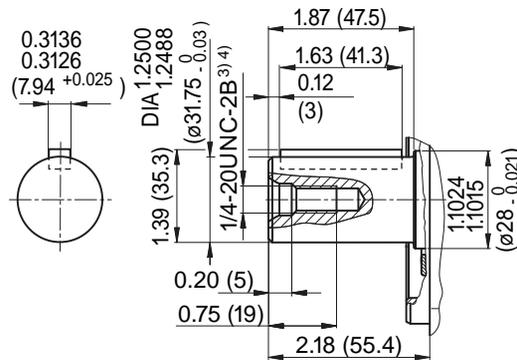

1) ANSI B92.1a, 30° pressure angle, flat root, side fit, tolerance class 5
 2) Splines according to ANSI B92.1a, run out of spline is a deviation from standard
 3) Thread according to ASME B1.1
 4) For the maximum tightening torques the general instructions on page A-64 must be observed.

Dimensions size 71

Before finalizing your design request a certified installation drawing.
Dimensions in inches and (mm).

DG
Two-point control, directly operated

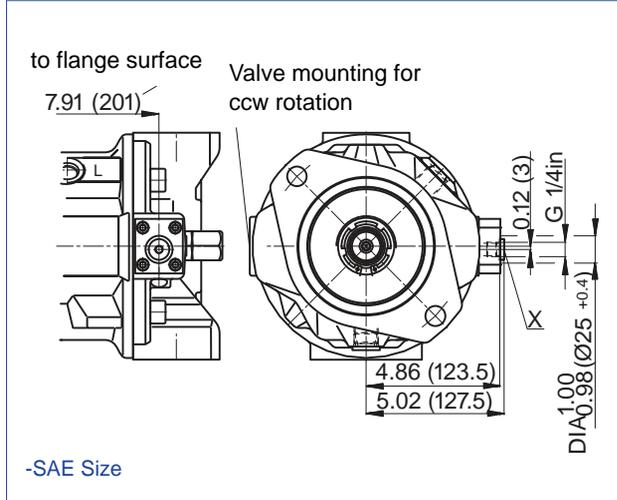

DFLR
Pressure, flow and power control

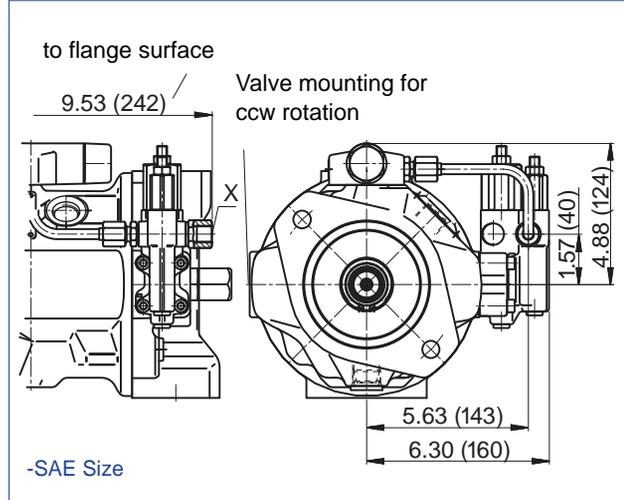

DR
Pressure control

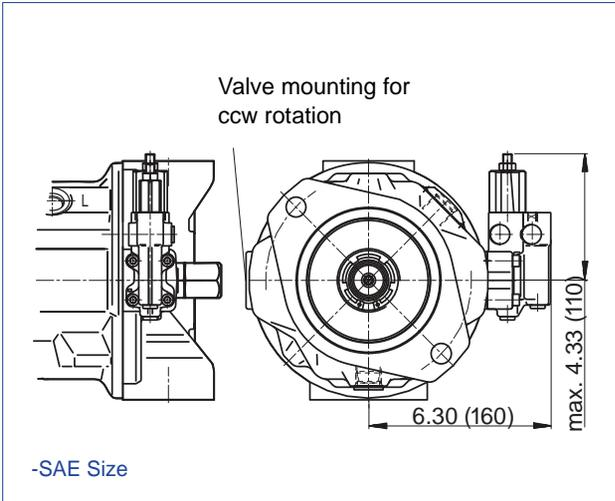

DRG
Pressure control, remotely operated

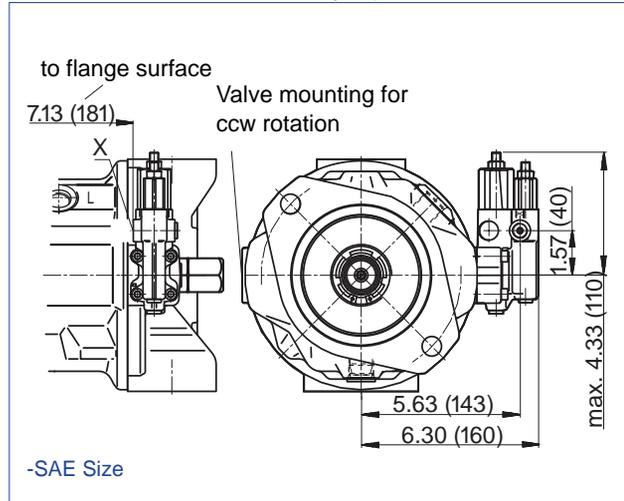

ED7. / ER7.
Electro-hydraulic pressure control

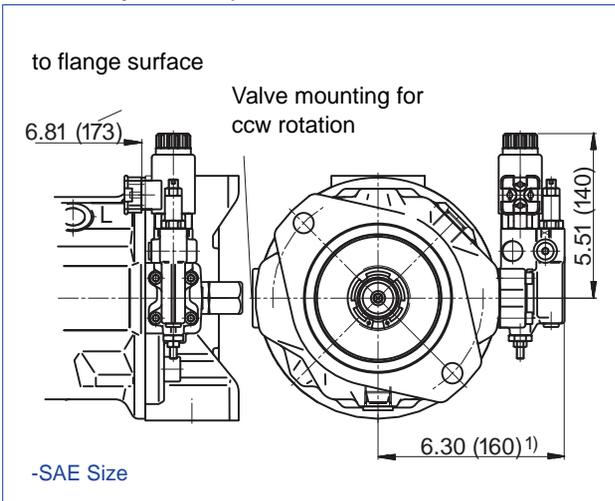

1) ER7.: 195 mm if using a sandwich plate pressure reducing valve.

Dimensions size 100

DFR/DFR1 – Pressure and flow control, hydraulic
Clockwise rotation

Before finalizing your design request a certified installation drawing.
Dimensions in inches and (mm).

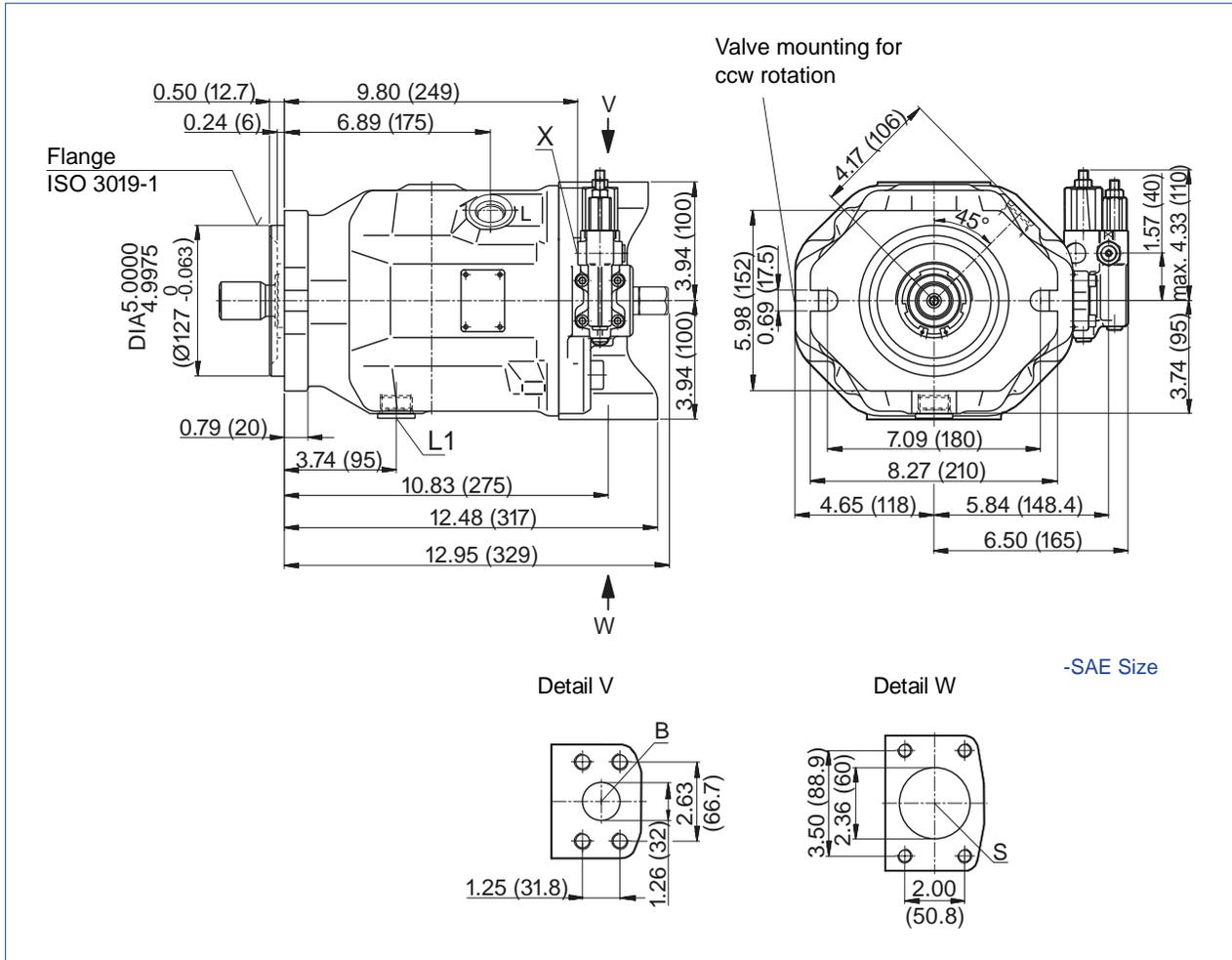

Ports

Designation	Port for	Standard	Size ¹⁾	Maximum pressure[psi(bar)] ²⁾	State
B	Service line, fastening thread	SAE J518 ASME B1.1	1 1/4 in 1/2-13 UNC-2B; 0.75 (19) deep	5100(350)	O
S	Suction line, fastening thread	SAE J518 ASME B1.1	2 1/2 in 1/2-13 UNC-2B; 1.06 (27) deep	145(10)	O
L	Case drain fluid	ISO 11926 ³⁾	1 1/16-12 UNF-2B; 0.63 (16) deep 30(2)		O ⁴⁾
L1	Case drain fluid	ISO 11926 ³⁾	1 1/16-12 UNF-2B; 0.63 (16) deep 30(2)		X ⁴⁾
X	Pilot pressure	ISO 11926 ³⁾	7/16-20 UNF-2B; 0.45 (12) deep	5100(350)	O
X	Pilot press. with DG-control	DIN ISO 228 ³⁾	G 1/4 in	5100(350)	O

- For the maximum tightening torques the general instructions on page A-64 must be observed.
- Depending on the application, short-term pressure spikes can occur. Keep this in mind when selecting measuring equipment and fittings. Pressure values in bar absolute.
- The spot face can be deeper than as specified in the standard.
- Depending on the installation position, L or L1 must be connected (the following page A-62 \ A-63, please check assambling instruction.)
O = Must be connected (plugged on delivery)
X = Plugged (in normal operation)

Dimensions size 100

Before finalizing your design request a certified installation drawing. Dimensions in inches and (mm).

Drive shaft

S
Splined shaft 1 1/2 in
17T 12/24DP ¹⁾(SAE J744)

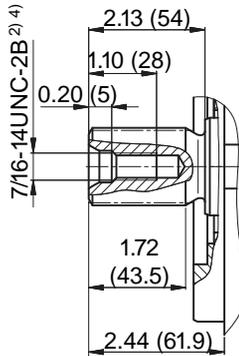

R
Splined shaft 1 1/4 in
14T 12/24DP ¹⁾(SAE J744)

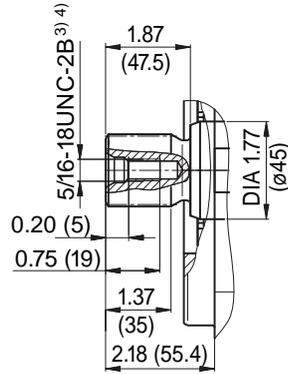

U
Splined shaft 1 1/4 in
14T 12/24DP ¹⁾(SAE J744)

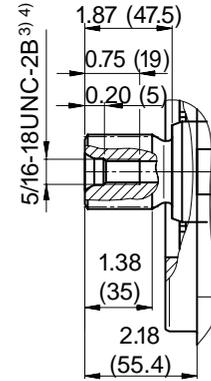

W
Splined shaft 1 1/4 in
14T 12/24DP ¹⁾(SAE J744)

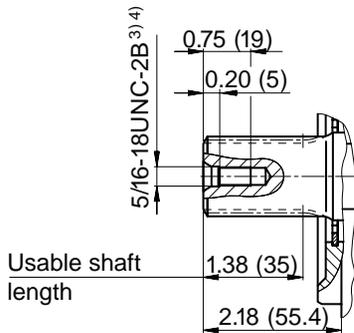

K
Parallel shaft key
ISO 3019-1, 38-1

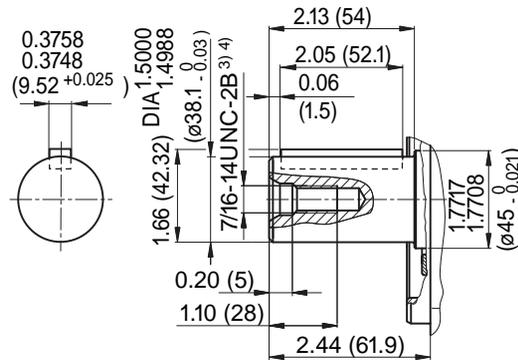

- 1) ANSI B92.1a, 30° pressure angle, flat root, side fit, tolerance class 5
- 2) Splines according to ANSI B92.1a, run out of spline is a deviation from standard
- 3) Thread according to ASME B1.1
- 4) For the maximum tightening torques the general instructions on page A-64 must be observed.

Dimensions size 100

A

53

PA10VSO - SAE Size

Before finalizing your design request a certified installation drawing. Dimensions in inches and (mm).

DG
Two-point control, directly operated

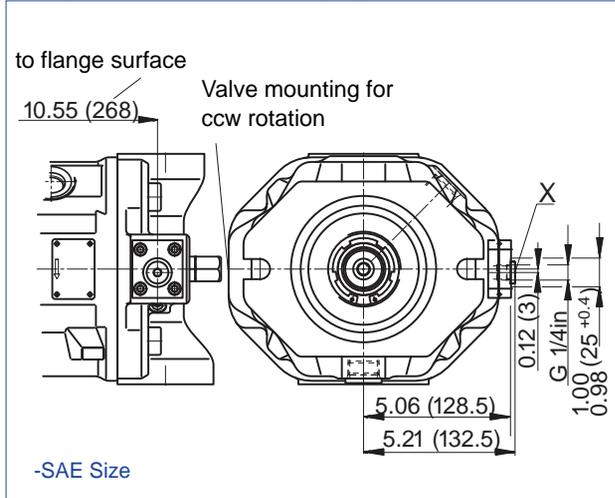

DFLR
Pressure, flow and power control

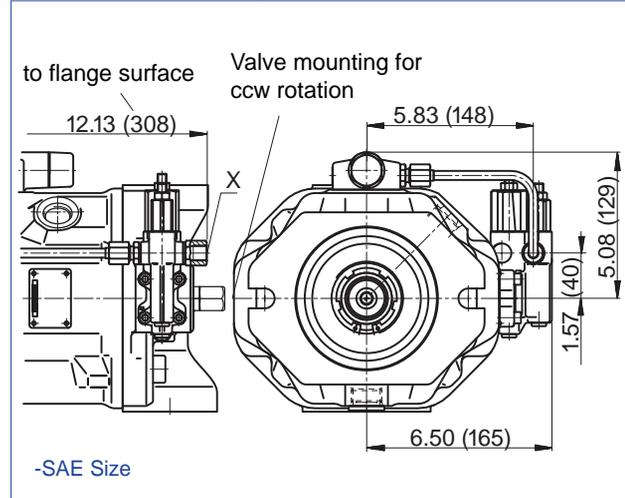

DR
Pressure control

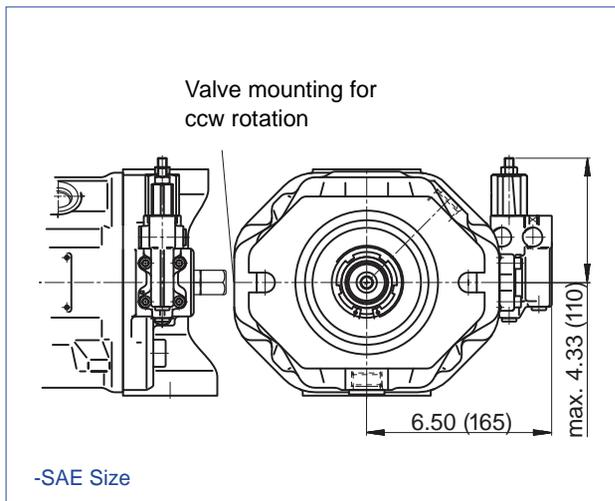

DRG
Pressure control, remotely operated

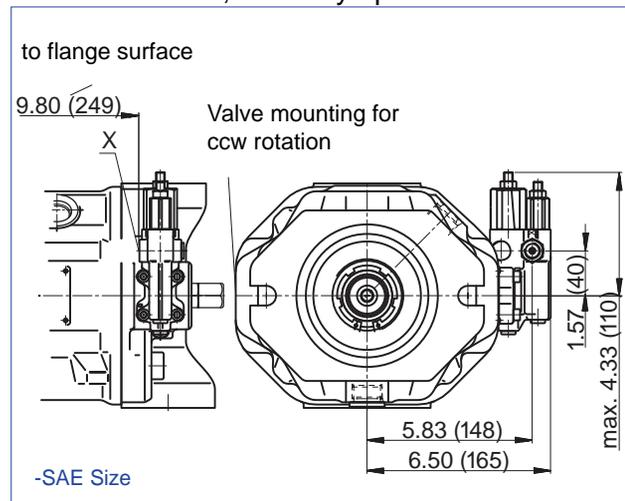

ED7. / ER7.
Electro-hydraulic pressure control

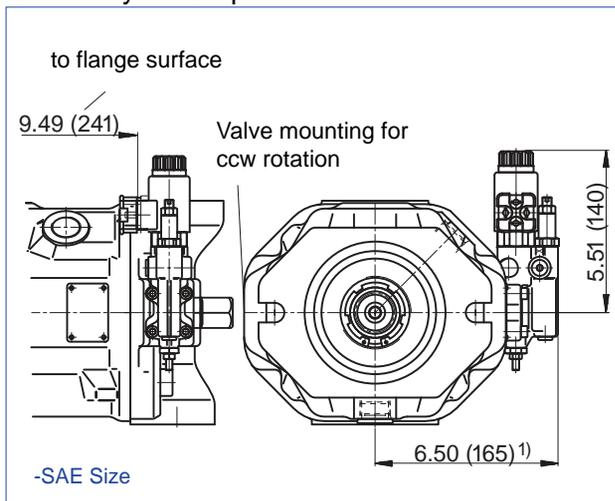

¹⁾ ER7.: 200 mm when using a sandwich plate pressure reducing valve.

Dimensions size 140

DFR/DFR1 — Pressure and flow control, hydraulic
Clockwise rotation

Before finalizing your design request a certified installation drawing.
Dimensions in inches and (mm).

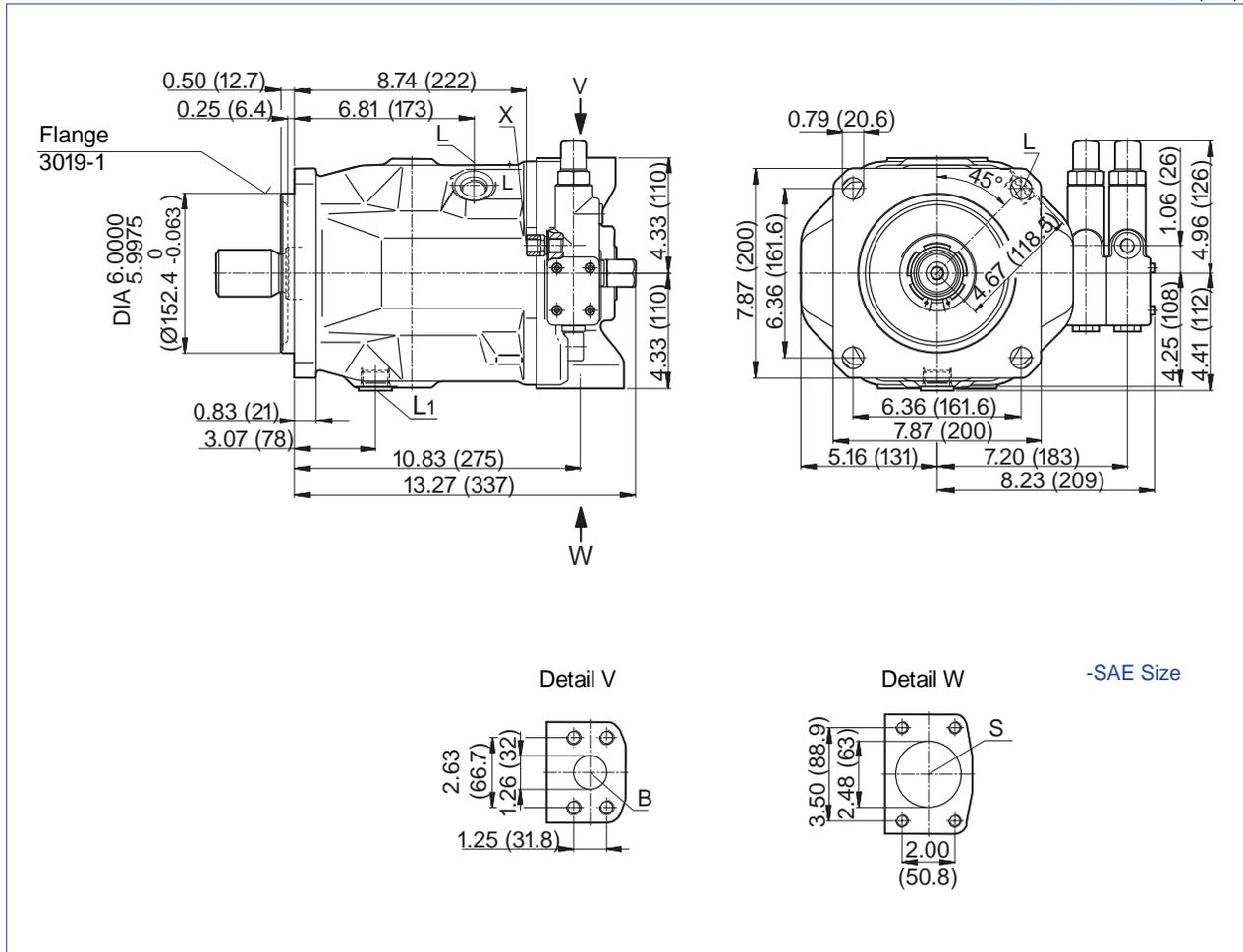

Ports

Designation	Port for	Standard	Size ¹⁾	Maximum pressure[psi(bar)] ²⁾	State
B	Service line, fastening thread	SAE J518 ASME B1.1	1 1/4 in 1/2-13 UNC-2B; 0.94 (24) deep	5100(350)	O
S	Suction line, fastening thread	SAE J518 ASME B1.1	2 1/2 in 1/2-13 UNC-2B; 0.94 (24) deep	145(10)	O
L	Case drain fluid	ISO 11926 ³⁾	1 1/16-12 UNF-2B; 0.63 (16) deep 30(2)		O ⁴⁾
L1	Case drain fluid	ISO 11926 ³⁾	1 1/16-12 UNF-2B; 0.63 (16) deep 30(2)		X ⁴⁾
X	Pilot pressure	ISO 11926 ³⁾	9/16-18 UNF-2B; 0.51 (13) deep	5100(350)	O
X	Pilot press. with DG-control	DIN ISO 228 ³⁾	M14 x 1.5; 0.47 (12) deep	5100(350)	O
MH	Gauge port, high pressure	DIN 3852	M14 x 1.5, 0.47 (12) deep	5100(350)	X

- 1) For the maximum tightening torques the general instructions on page A-64 must be observed.
- 2) Depending on the application, short-term pressure spikes can occur. Keep this in mind when selecting measuring equipment and fittings. Pressure values in bar absolute.
- 3) The spot face can be deeper than as specified in the standard.
- 4) Depending on the installation position, L or L1 must be connected (the following page A-62 \ A-63, please check assambling instruction.)
O = Must be connected (plugged on delivery)
X = Plugged (in normal operation)

Dimensions size 140

Drive

Before finalizing your design request a certified installation drawing. Dimensions in inches and (mm).

S

Splined shaft 1 3/4 in
13T 8/16DP¹⁾ (SAE J744)

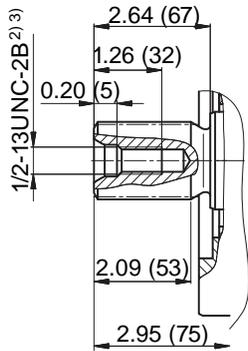

K

Parallel shaft key
ISO 3019-1, 44-1

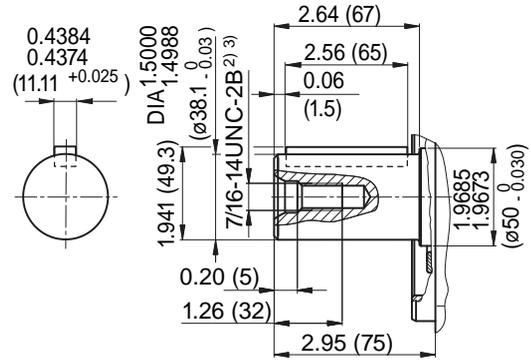

¹⁾ ANSI B92.1a, 30° pressure angle, flat root, side fit, tolerance class 5

²⁾ Thread according to ASME B1.1

³⁾ For the maximum tightening torques the general instructions on page A-64 must be observed.

Dimensions size 140

Before finalizing your design request a certified installation drawing.
Dimensions in inches and (mm).

DG
Two-point control, directly operated

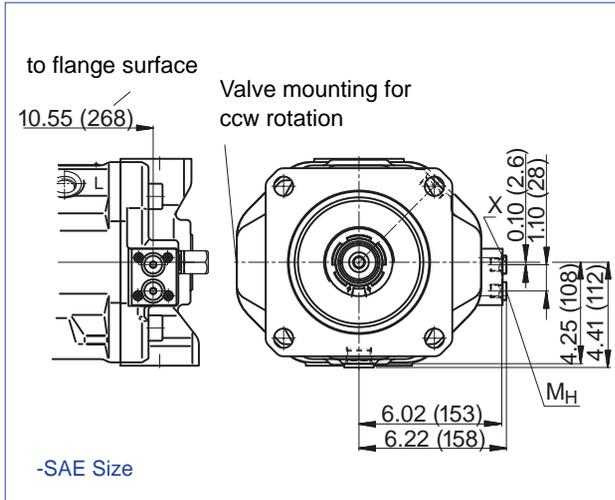

DFLR
Pressure, flow and power control

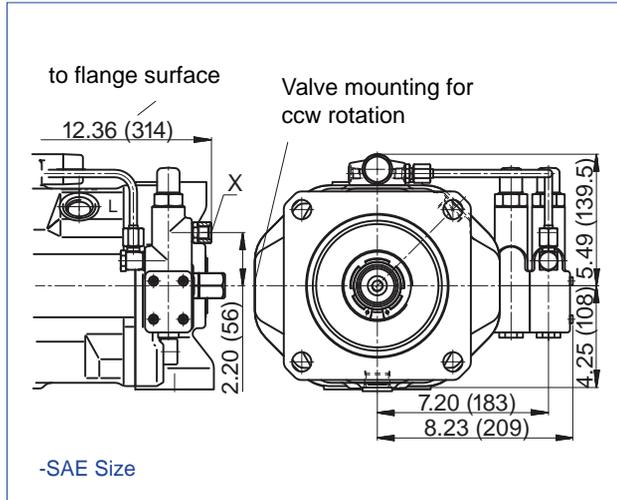

DR
Pressure control

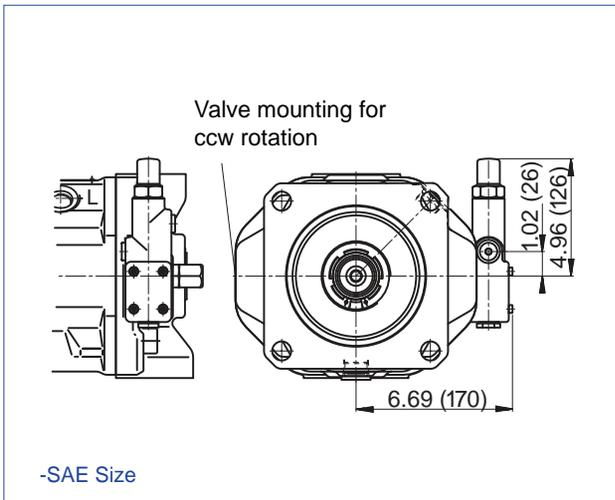

DRG
Pressure control, remotely operated

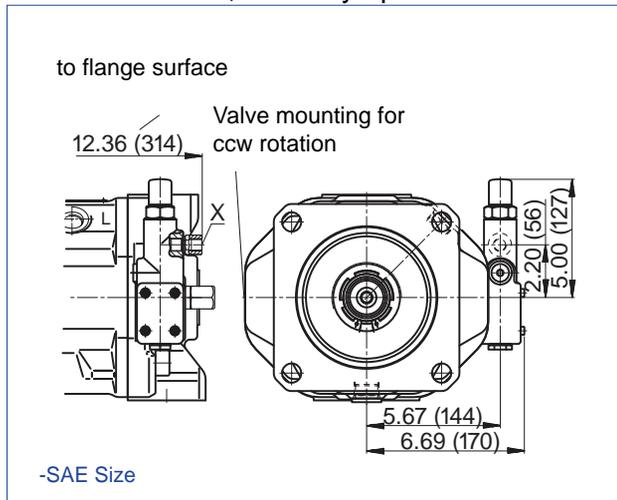

ED7. / ER7.
Electro-hydraulic pressure control

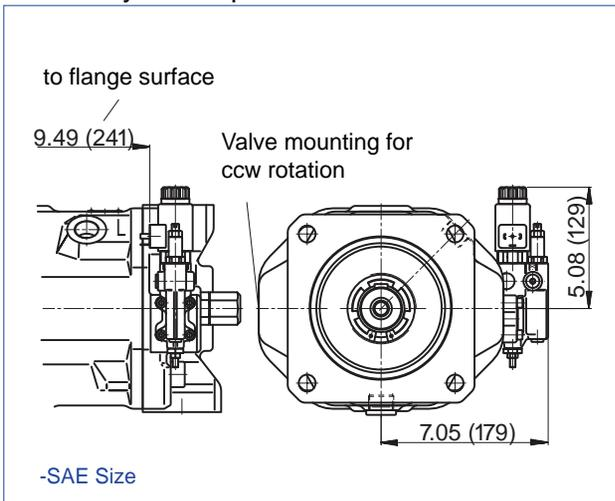

¹⁾ ER7.: 214 mm when using a sandwich plate pressure reducing valve.

Dimensions through drive

A

57

PA10VSO - SAE Size

K01 flange ISO 3019-1 (SAE J744 - 82-2 (A))
Coupling for splined shaft according to ANSI B92.1a

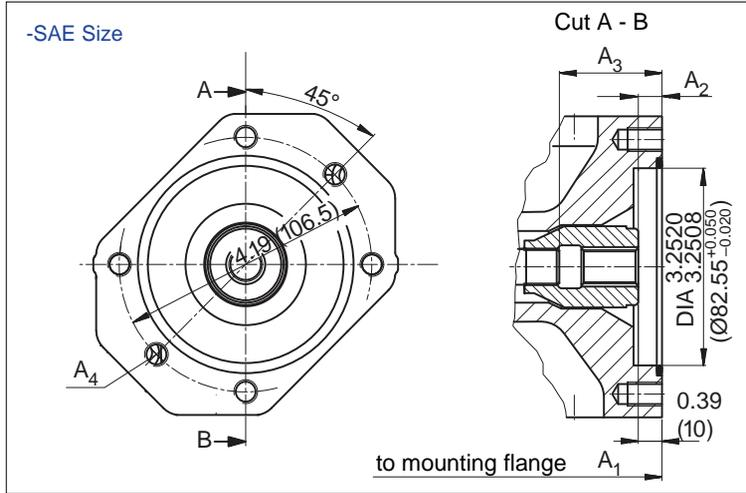

5/8 in 9T 16/32 DP¹⁾(SAE J744 - 16-4 (A))

NG	A ₁	A ₂	A ₃	A ₄ ²⁾
18	7.16 (182)	0.39 (10)	1.70 (43.3)	M10 x 1.5, 0.57 (14.5) deep
28	8.03 (204)	0.39 (10)	1.33 (33.7)	M10 x 1.5, 0.62 (16) deep
45	9.02 (229)	0.42 (10.7)	2.10 (53.4)	M10 x 1.5, 0.62 (16) deep
71	10.51 (267)	0.46 (11.8)	2.41 (61.3)	M10 x 1.5, 0.78 (20) deep
100	13.31 (338)	0.41 (10.5)	2.56 (65)	M10 x 1.5, 0.62 (16) deep
140	13.78 (350)	0.43 (10.8)	3.04 (77.3)	M10 x 1.5, 0.62 (16) deep

K52 flange ISO 3019-1 (SAE J744 - 82-2 (A))
Coupling for splined shaft according to ANSI B92.1a

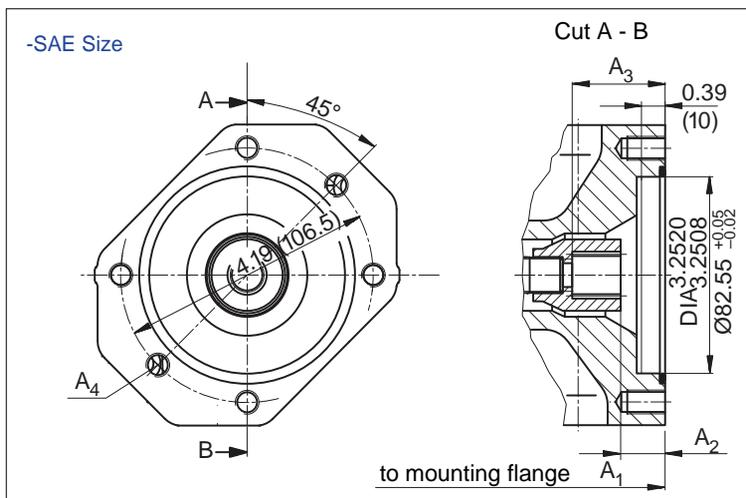

3/4 in 11T 16/32 DP¹⁾(SAE J744 - 19-4 (A-B))

NG	A ₁	A ₂	A ₃	A ₄ ²⁾
18	7.16 (182)	0.74 (18.8)	1.52 (38.7)	M10 x 1.5, 0.57 (14.5) deep
28	8.03 (204)	0.74 (18.8)	1.52 (38.7)	M10 x 1.5, 0.62 (16) deep
45	9.02 (229)	0.744 (18.9)	1.52 (38.7)	M10 x 1.5, 0.62 (16) deep
71	10.51 (267)	0.84 (21.3)	1.63 (41.4)	M10 x 1.5, 0.78 (20) deep
100	13.31 (338)	0.75 (19)	1.53 (38.9)	M10 x 1.5, 0.62 (16) deep
140	13.78 (350)	0.744 (18.9)	1.52 (38.6)	M10 x 1.5, 0.62 (16) deep

K68 flange ISO 3019-1 (SAE J744 - 101-2 (B))
Coupling for splined shaft according to ANSI B92.1a

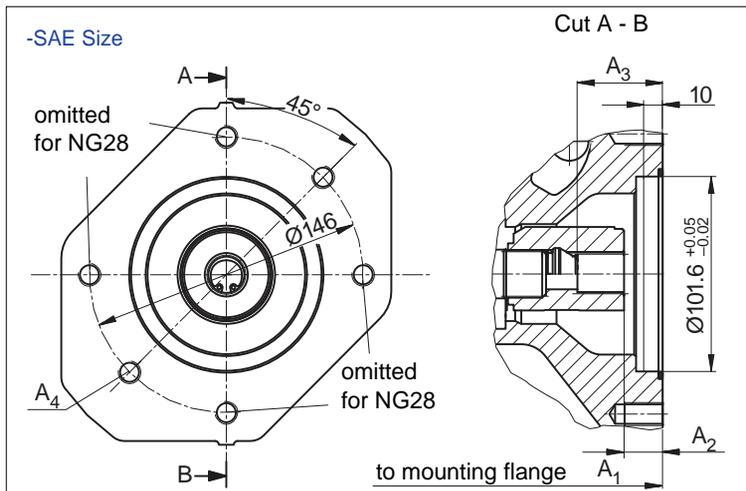

7/8 in 13T 16/32 DP¹⁾(SAE J744 - 22-4 (B))

NG	A ₁	A ₂	A ₃	A ₄ ²⁾
28	8.03 (204)	0.70 (17.8)	1.64 (41.7)	M12 x 1.75, continuous
45	9.02 (229)	0.704 (17.9)	1.64 (41.7)	M12 x 1.75, 0.71 (18) deep
71	10.51 (267)	0.80 (20.3)	1.74 (44.1)	M12 x 1.75, 0.78 (20) deep
100	13.31 (338)	0.71 (18)	1.65 (41.9)	M12 x 1.75, 0.78 (20) deep
140	13.78 (350)	0.70 (17.8)	1.64 (41.6)	M12 x 1.75, 0.78 (20) deep

1) 30° pressure angle, flat root, side fit, tolerance class 5

2) Thread according to DIN 13, observe the general instructions on page A-64 for the maximum tightening torques.

Dimensions through drive

K04 flange ISO 3019-1 (SAE J744 - 101-2 (B))
Coupling for splined shaft according to ANSI B92.1a

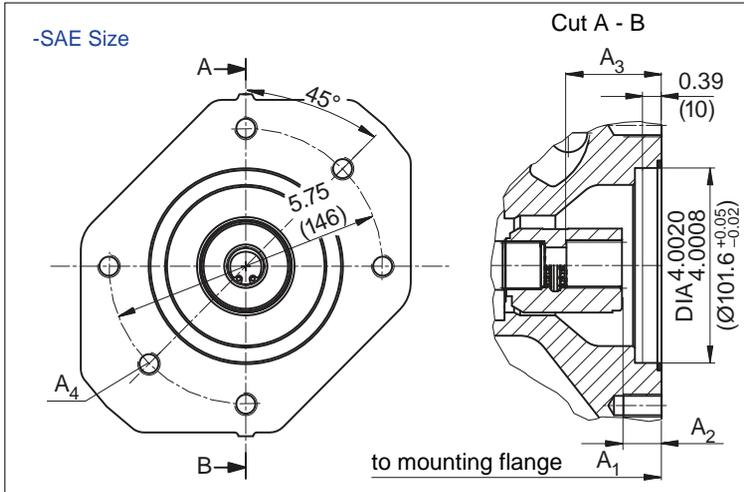

K07 flange ISO 3019-1 (SAE J744 - 127-2 (C))
Coupling for splined shaft according to ANSI B92.1a

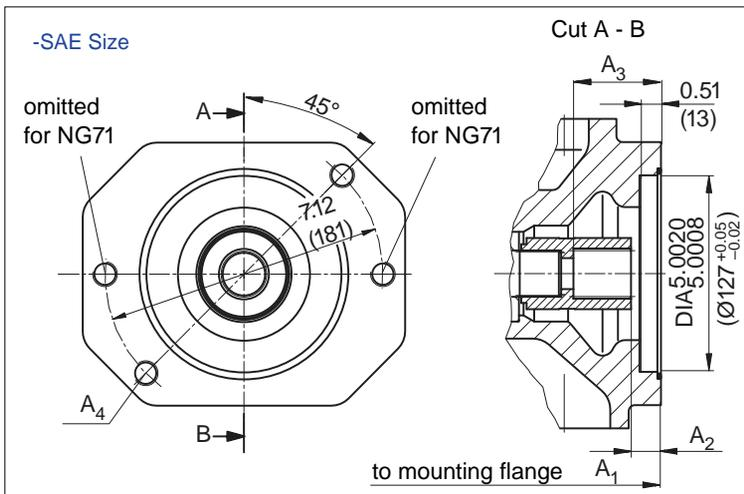

K24 flange ISO 3019-1 (SAE J744 - 127-2 (C))
Coupling for splined shaft according to ANSI B92.1a

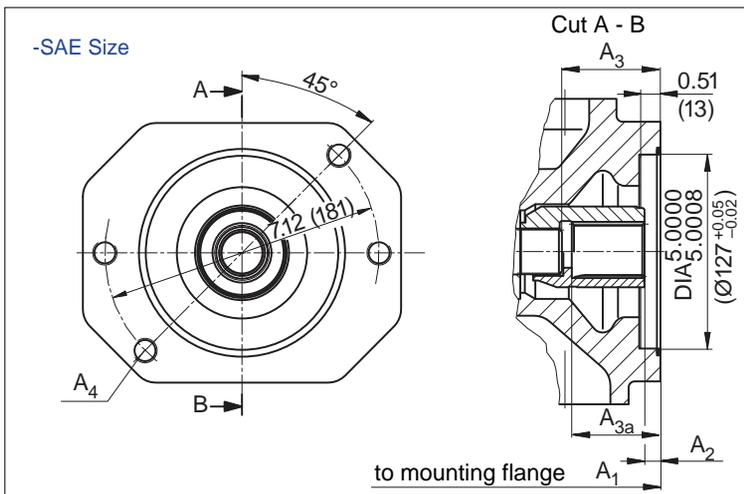

Before finalizing your design request a certified installation drawing.
Dimensions in inches and (mm).

1 in 15T 16/32 DP¹⁾(SAE J744 - 25-4 (B-B))

NG	A ₁	A ₂	A ₃	A ₄ ²⁾
45	9.02 (229)	0.724 (18.4)	1.84 (46.7)	M12 x 1.75, 0.71 (18) deep
71	10.51 (267)	0.82 (20.8)	1.93 (49.1)	M12 x 1.75, 0.78 (20) deep
100	13.31 (338)	0.716 (18.2)	1.83 (46.6)	M12 x 1.75, 0.78 (20) deep
140	13.78 (350)	0.72 (18.3)	1.81 (45.9)	M12 x 1.75, 0.78 (20) deep

1 1/4 in 14T 12/24 DP¹⁾(SAE J744 - 32-4 (C))

NG	A ₁	A ₂	A ₃	A ₄ ²⁾
71	10.51 (267)	0.86 (21.8)	2.31 (58.6)	M16 x 2, continuous
100	13.31 (338)	0.77 (19.5)	2.22 (56.4)	M16 x 2, continuous
140	13.78 (350)	0.76 (19.3)	2.21 (56.1)	M16 x 2, 0.94 (24) deep

1 1/2 in 17T 12/24 DP¹⁾(SAE J744 - 38-4 (C-C))

NG	A ₁	A ₂	A ₃ ³⁾	A _{3a} ⁴⁾	A ₄ ²⁾
100	13.31 (338)	0.41 (10.5)	2.56 (65)	-	M16 x 2, continuous
140	13.78 (350)	0.42 (10.8)	2.95 (75)	-	M16 x 2, 0.94 (24) deep
	13.78 (350)	0.40 (10.3)	-	2.72 (69.1)	M16 x 2, 0.94 (24) deep

- 3) Coupling without stop
- 4) Coupling with stop

1) 30° pressure angle, flat root, side fit, tolerance class 5
2) Thread according to DIN 13, observe the general instructions on page A-64 for the maximum tightening torques.

Dimensions through drive

K17 flange ISO 3019-1 (SAE J744 - 152-4 (A))
Coupling for splined shaft according to ANSI B92.1a

Before finalizing your design request a certified installation drawing.
Dimensions in inches and (mm).

A

59

PA10VSO - SAE Size

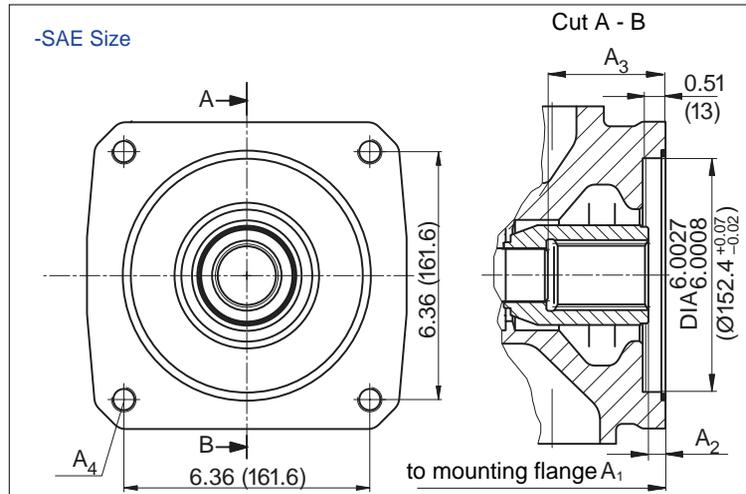

1 3/4 in 13T 8/16 DP¹⁾(SAE J744 - 44-4 (D))

NG	A ₁	A ₂	A ₃	A ₄ ²⁾
140	13.78 (350)	0.43 (11)	3.04 (77.3)	M6 x 2, continuous

- 1) 30° pressure angle, flat root, side fit, tolerance class 5
- 2) Thread according to DIN 13, observe the general instructions on page A-64 for the maximum tightening torques.

Summary mounting options

ISO (Metric) — mounting flange

Through-drive ¹⁾ Flange ISO 3019-2	Coupling for splined shaft	Short des. KB	Mounting option – 2nd pump			
			PA10VO/31 NG (shaft)	PA10V(S)O/5x NG (shaft)	Gear pump design(NG)	Through drive available for NG
80-2	3/4 in	KB2	18 (S · R)	10 (S)	–	18 to 140
100-2	7/8 in	KB3	28 (S · R)	–	–	28 to 140
	1 in	KB4	45 (S · R)	–	–	45 to 140
125-2	1 1/4 in	KB5	71 (S · R)	–	–	71 to 140
	1 1/2 in	KB6	100 (S)	–	–	100 to 140
180-4 (4-holeB)	1 3/4 in	KB7	140 (S)	–	–	140

Parallel shaft key

Through-drive ¹⁾ Flange ISO 3019-2	Coupling for splined shaft	Short des. K	Mounting option – 2nd pump			
			PA10VO/31 NG (shaft)	PA10V(S)O/5x NG (shaft)	Radial piston pump	Through drive available for NG
80-2	3/4 in	K57	–	–	R4	28 to 140

SAE — mounting flange

Through-drive ¹⁾ Flange ISO 3019-1	Coupling for splined shaft	Short des. K	Mounting option – 2nd pump			
			PA10VO/31 NG (shaft)	PA10V(S)O/5x NG (shaft)	Gear pump design(NG)	Through drive available for NG
82-2 (A)	5/8 in	K01	18 (U)	10 (U)	F (5 to 22)	18 to 140
	3/4 in	K52	18 (S · R)	10 (S) 18 (U) 18 (S · R)	–	18 to 140
101-2 (B)	7/8 in	K68	28 (S · R) 45 (U · W) ¹⁾	28 (S · R) 45 (U · W) ¹⁾	N/G (26 to 49)	28 to 140
	1 in	K04	45 (S · R) –	45 (S · R) 60 · 63 (U · W) ²⁾	–	45 to 140
127-2 (C)	1 1/4 in	K07	71 (S · R) 100 (U) ³⁾	85 (U · W) ³⁾ 100 (U · W)	–	71 to 140
	1 1/2 in	K24	100 (S)	85 (S) 100 (S)	–	100 to 140
152-4 (4-hole D)	1 3/4 in	K17	140 (S)	–	–	140

1) Not for main pump NG28 with K68

2) Not for main pump NG45 with K04

3) Not for main pump NG71 with K07

Combination pumps PA10VO + PA10VO

A

61

PA10VSO

When using combination pumps it is possible to have multiple, mutually independent circuits without the need for a splitter gearbox.

When ordering combination pumps the model codes for the first and the second pump must be joined by a "+".

Order example :

PA10VSO100DFR1/31R-VSB12K04+

PA10VSO45DFR/31R-VSA12N00

If no further pumps are to be factory-mounted, the simple type code is sufficient. Included in the delivery contents of the pump with through drive are then: coupling and seal, with plastic cover to prevent penetration by dust and dirt.

It is permissible to use a combination of two single pumps of the same size (tandem pump), considering a dynamic mass acceleration force of maximum 10 g (= 98.1 m/s²) without an additional support bracket.

Each through drive is plugged with a non-pressure-resistant cover. Before commissioning the units, they must therefore be equipped with a pressure-resistant cover.

Through drives can also be ordered with pressure-resistant covers. Please specify in clear text.

For combination pumps comprising more than two pumps, the mounting flange must be calculated for the permissible moment of inertia.

Permissible mass moment of inertia

NG		18	28	45	71	100	140
Permissible mass moment of inertia static	T_m lb-ft (Nm)	369 (500)	649 (880)	1010 (1370)	1593 (2160)	2213 (3000)	3319 (4500)
	dynamic at 10g (98.1 m/s ²)	T_m lb-ft (Nm)	37 (50)	65 (88)	101 (137)	159 (216)	221 (300)
Mass with through-drive plate	m lbs (kg)	30.8 (14)	41.9 (19)	55 (25)	86 (39)	119 (54)	150 (68)
Mass without through drive (e.g. 2nd pump)	m lbs (kg)	26.6 (12)	33 (15)	46 (21)	73 (33)	99 (45)	132 (60)
Distance center of gravity	l in (mm)	3.54 (90)	4.33 (110)	5.12 (130)	5.91 (150)	6.30 (160)	6.30 (160)

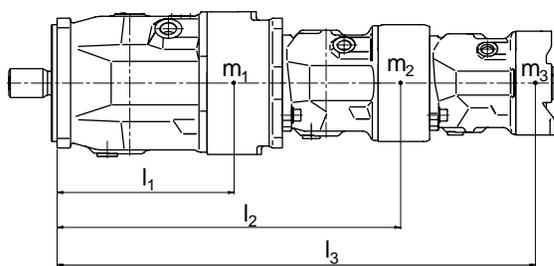

$m_1 \cdot m_2 \cdot m_3$ Mass of pumps [lbs (kg)]

$l_1 \cdot l_2 \cdot l_3$ Distance center of gravity [in (mm)]

$$T_m = (m_1 \cdot l_1 + m_2 \cdot l_2 + m_3 \cdot l_3) \cdot \frac{1}{12(102)} \text{ [lb-ft (Nm)]}$$

Installation instructions

General

The axial piston unit must be filled with hydraulic fluid and air bled during commissioning and operation. This must also be observed following a longer standstill as the axial piston unit empty via the hydraulic lines.

Especially with the installation position "drive shaft upwards" or "drive shaft downward", attention must be paid to a complete filling and air bleeding since there is a risk, for example, of dry running.

The case drain fluid in the motor housing must be directed to the reservoir via the highest case drain port (L1, L2, L3).

For combinations of multiple units, make sure that the respective case pressure in each unit is not exceeded. In the event of pressure differences at the case drain ports of the units, the shared case drain line must be changed so that the minimum permissible case pressure of all connected units is not exceeded in any situation. If this is not possible, separate case drain lines must be laid if necessary.

To achieve favorable noise values, decouple all connecting lines using elastic elements and avoid above-reservoir installation.

In all operating conditions, the suction line and case drain line must flow into the reservoir below the minimum fluid level. The permissible suction height h_S is a result of the overall pressure loss, but may not be greater than $h_{S \max} = 31.50$ inch (800 mm). The minimum suction pressure at port S must also not fall below 12 psi (0.8 bar) absolute during operation.

Installation position

See the following examples 1 to 12.

Additional installation positions are available upon request. Recommended installation positions: 1 and 3.

Below-reservoir installation (standard)

Below-reservoir installation means the axial piston unit is installed outside of the reservoir below the minimum fluid level.

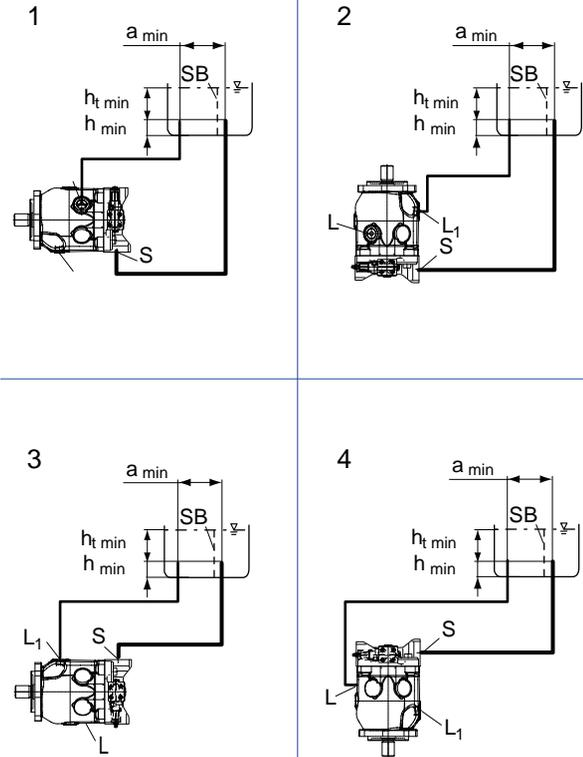

Installation position	Air bleed	Filling
1	L	S + L ₁
2	L ₁	S + L
3	L ₁	S + L
4	L	S + L ₁

please following page A-63.

Installation instructions

A

63

PA10VSO

Above-reservoir installation

Above-reservoir installation means the axial piston unit is installed above the minimum fluid level of the reservoir.

To prevent the axial piston unit from draining, a height difference $h_{ES\ min}$ of at least 0.98 inch (25 mm) at port L 1 is required in installation position 6. Observe the maximum permissible suction height $h_{S\ max} = 31.50$ inches (800 mm)

A check valve in the case drain line is only permissible in individual cases. Consult us for approval.

Inside-reservoir installation

Inside-reservoir installation is when the axial piston unit is installed in the reservoir below the minimum fluid level.

The axial piston unit is completely below the hydraulic fluid.

If the minimum fluid level is equal to or below the upper edge of the pump, see chapter "Above-reservoir installation".

Axial piston units with electrical components (e.g. electric control, sensors) may not be installed in a reservoir below the fluid level.

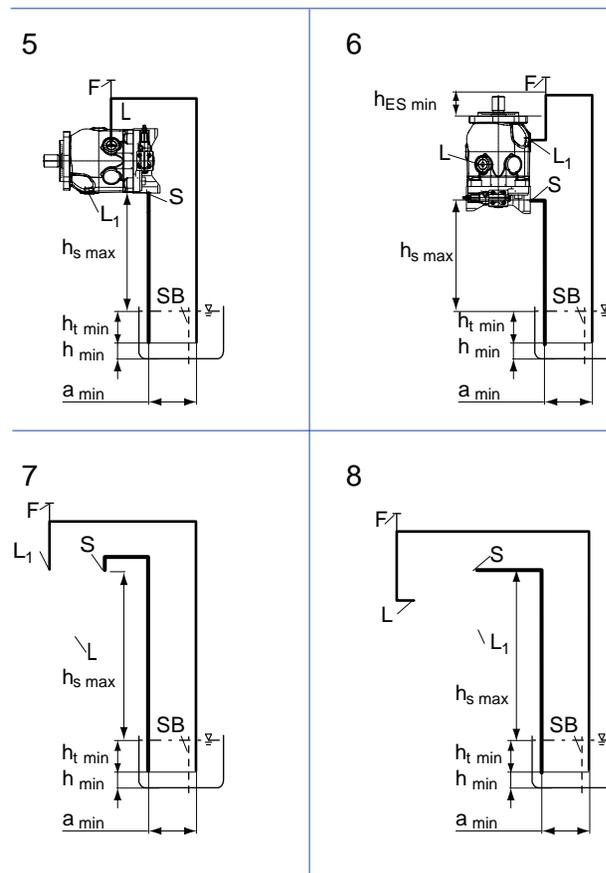

Installation position	Air bleed	Filling
5	F	L (F)
6	F	L ₁ (F)
7	F	S + L ₁ (F)
8	F	S + L (F)

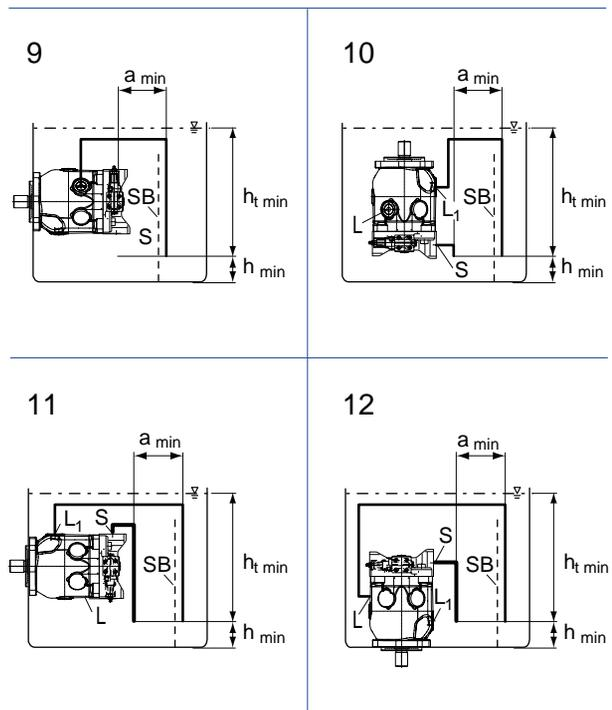

Installation position	Air bleed	Filling
9	L	L · L ₁
10	L ₁	L · L ₁
11	L ₁	S + L · L ₁
12	L	S + L · L ₁

S	Suction port
F	Filling / air bleeding
L · L ₁	Case drain port
SB	Baffle (baffle plate)
$h_{t\ min}$	Minimum necessary immersion depth (7.87 inch (200 mm))
h_{min}	Minimum necessary spacing to reservoir bottom (3.94 inch (100 mm))
$h_{ES\ min}$	Minimum necessary height needed to protect the axial piston unit from draining (0.98 inches (25 mm)).
$h_{S\ max}$	Maximum permissible suction height (31.50 inch (800 mm))
a_{min}	When designing the reservoir, ensure adequate distance between the suction line and the case drain line. This prevents the heated, return flow from being drawn directly back into the suction line.

Tightening torques

- Fittings:

Observe the manufacturer's instruction regarding the tightening torques of the used fittings.

- Mounting bolts:

For mounting bolts with metric ISO thread according to DIN 13 or thread according to ASME B1.1

- Female threads in axial piston unit :

The maximum permissible tightening torques $M_{G \max}$ are maximum values for the female threads and must not be exceeded. For values, see the following table.

- Threaded plugs :

For the metal threaded plugs supplied with the axial piston unit, the required tightening torques of the threaded plugs M_V apply. For values, see the following table.

Metric Ports Standard	Thread size	Maximum permissible tightening torque for female threads $M_{G \max}$	Required tightening torque for threaded plugs M_V	Size of hexagon socket of threaded plugs
DIN 385	M14 x 1.5	80 Nm	45 Nm	6 mm
	M16 x 1.5	100 Nm	50 Nm	8 mm
	M18 x 1.5	140 Nm	60 Nm	8 mm
	M22 x 1.5	210 Nm	80 Nm	10 mm
	M27 x 2	330 Nm	135 Nm	12 mm
DIN ISO 228	G 1/4 in	70 Nm	–	–

SAE Ports Standard	Thread size	Maximum permissible tightening torque for female threads $M_{G \max}$	Required tightening torque for threaded plugs M	Size of hexagon socket of threaded plugs
DIN 3852 ¹⁾	G1/4	52 lb-ft	–	–
		70 Nm	–	–
	M14 x 1.5	59 lb-ft	26 lb-ft	0.24 inch
		80 Nm	35 Nm	6 mm
DIN ISO 228	G1/4	52 lb-ft	22 lb-ft	0.24 inch
		70 Nm	30 Nm	6 mm
ISO 11926	7/16-20UNF-2B	29 lb-ft	13 lb-ft	3/16 in
		40 Nm	18 Nm	
	9/16-18UNF-2B	59 lb-ft	26 lb-ft	1/4 in
		80 Nm	35 Nm	
	3/4-16UNF-2B	118 lb-ft	52 lb-ft	5/16 in
		160 Nm	70 Nm	
	7/8-14UNF-2B	177 lb-ft	81 lb-ft	3/8 in
		240 Nm	110 Nm	
	1 1/16-12UN-2B	266 lb-f	125 lb-f	9/16 in
		360 Nm	170 Nm	

¹⁾The tightening torques of the threaded plugs M_V apply for screws in the „dry“ state as received on delivery and in the „lightly oiled“ state for installation

General instructions

A

65

PA10VSO

- The PA10VSO pump is designed to be used in open circuit.
- Project planning, installation and commissioning of the axial piston unit require the involvement of qualified personnel.
- Before operating the axial piston unit, please read the appropriate instruction manual thoroughly and completely. If necessary, request these from DYNATEC.
- During and shortly after operation, there is a risk of burns on the axial piston unit and especially on the solenoids. Take appropriate safety measures (e.g. by wearing protective clothing).
- Depending on the operating conditions of the axial piston unit (operating pressure, fluid temperature), the characteristics may shift.
- Service line ports:
 - The ports and fastening threads are designed for the specified maximum pressure. The machine or system manufacturer must ensure that the connecting elements and lines correspond to the specified application conditions (pressure, flow, hydraulic fluid, temperature) with the necessary safety factors.
 - The service line ports and function ports are only designed to accommodate hydraulic lines.
- Pressure cut-off and pressure control do not provide security against pressure overload. A separate pressure relief valve is to be provided in the hydraulic system.
- The data and notes contained herein must be adhered to.
- The product is not approved as a component for the safety concept of a general machine according to ISO 13849 / DIN EN ISO 13849.